



BOILER BLOWDOWN WASTE MANAGEMENT

BLOWDOWN SEPARATORS



Designed, constructed and stamped in accordance with the requirements of the ASME Boiler Codes.

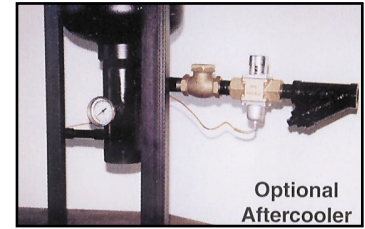

Optional
Aftercooler



The HBC Blowdown Separator is designed to take water from the boiler during blowdown and reduce it to atmospheric pressure for disposal. The HBC Separator accomplishes this by separating the subsequent flashed steam from the hot water. As the blowdown enters the vessel, it is forced into a centrifugal pattern by means of a striking plate. The steam is vented to the atmosphere through a top connection. The HBC Separator is built as per requirements Section VIII of the ASME Code and stamped by the National Board of Pressure Vessel Inspectors. The HBC Blowdown Separator provides an economical means of safe boiler blowdown.

The separator includes a structural steel support stand for mounting to foundation. Options available are aftercooler, manual cooling valve assembly, automatic cooling valve assembly, and exhaust heads.

■ **HURST PERFORMANCE BOILERS & ACCESSORIES** ■

BLOWDOWN SEPARATORS

HURST BLOWDOWN SEPARATORS are built to Section VIII, Division 1 of the ASME Code for 250 PSI design pressure.

(200 PSI design pressure with 150# ANSI flanges)

Blowdown separator design pressure should be a minimum of 25% of the boiler maximum allowable working pressure (MAWP) as recommended by the National Board.

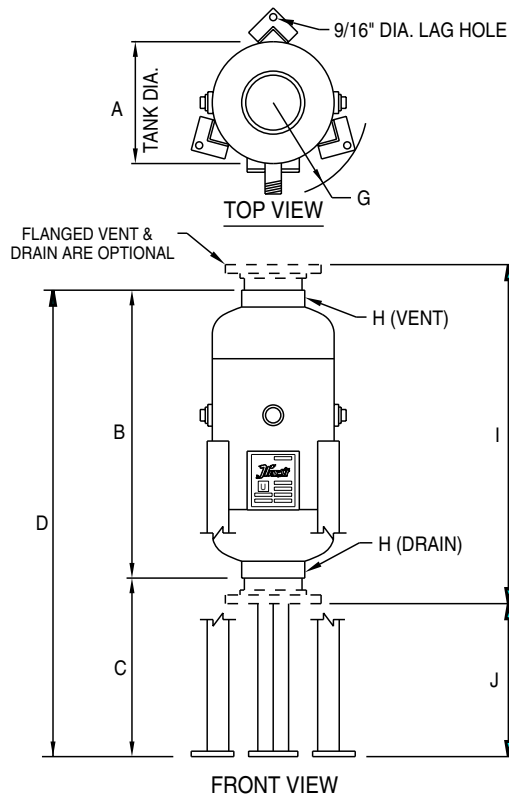
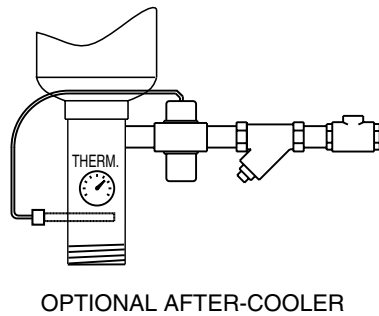
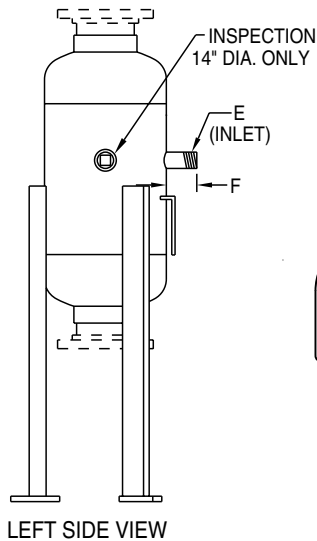

SPECIFICATIONS

(ALL DIMENSIONS ARE IN INCHES)

THREADED VENT & DRAIN STANDARD, FLANGED OPTIONAL

DIMENSIONS SUBJECT TO CHANGE WITHOUT NOTICE, CERTIFIED DRAWINGS AVAILABLE UPON REQUEST.

BOILER TAIL PIPE DIMENSION		3/4 - 1 1/4 ECONOMY	3/4 - 1 1/2 BLOWDOWN	1 1/4 BLOWDOWN	1 1/2 - 2 BLOWDOWN	2 - 2 1/2 BLOWDOWN
BDS. MODEL NUMBER		BDS8 (SEE NOTE 1)	BD14X24	BD14X34	BD14X34A	BD14X56
A	TANK DIAMETER	8	14	14	14	14
B	LENGTH	26	24	34	34	56
C	DRAIN TO FLOOR	16	24	24	24	24
D	OVERALL HEIGHT	42	48	60	58 1/4	80
E	INLET SIZE	1 1/4	1 1/2	1 1/4	2	2 1/2
F	INLET LENGTH	3	3 1/2	3 1/2	3 1/2	3 1/2
G	OVERALL RADIUS	7 1/2	10 7/8	10 7/8	10 7/8	10 7/8
H	VENT & DRAIN	2 1/2	2 1/2	3	4	6
I	LENGTH W/FLG.	32 1/2	30 1/2	40	40	62
J	FLANGE TO FLOOR	13	21	21	21	21
	WEIGHT NET/SHIPPING LBS.	80/100	180/200	250/275	250/275	355/395

NOTE: 8" DIAMETER SEPARATORS ARE DESIGNED FOR BOILERS NEEDING SHORT DURATION BLOWDOWN ONLY.
(SUCH AS VERTICAL TUBELESS BOILERS)

hurstboiler.com

Represented by:



P. O. Drawer 530
21971 US. Highway 319 N.
Coolidge, Georgia 31738
1-877-994-8778 (Toll Free)
(229) 346-3545 (Tel.)
(229) 346-3874 (Fax.)
e-mail: info@hurstboiler.com

Revised 02/03-BPC