

ELECTRIC

RESISTANCE BOILERS

Steam or Hot Water



Boiler Book
03/2021



CONTENTS

FEATURES AND BENEFITS	3
PRODUCT OFFERING	4
DIMENSIONS AND RATINGS	9
PERFORMANCE DATA	29
ENGINEERING DATA	29

List of Figures

Model WB Dimensions	9
Model S Dimensions	10
Model CR Dimensions	11
Model HSB Dimensions	12

List of Tables

Standard Product Offering	8
Model WB Ratings 208V, 240V Supplies	13
Model WB Ratings 380V, 415V Supplies	14
Model WB Ratings 480V, 600V Supplies	17
Model S/CR Ratings 208V Supply	19
Model S/CR Ratings 240V Supply	20
Model S/CR Ratings 380V, 415V Supplies	21
Model S/CR Ratings 480V Supply	22
Model S/CR Ratings 600V Supply	24
Model HSB Ratings 380V, 415V Supplies	26
Model HSB Ratings 480V Supply	26
Model HSB Ratings 600V Supply	27
Model WB Max Flow Ratings	30
Model WB Minimum Over Pressure Requirements	32
kW per Pound of Steam	33
Recommended Steam Nozzle Sizes	33
Water Quality	34
Power Distribution Blocks	35
Disconnect Terminal Lugs	35
Grounding Lugs	35

FEATURES AND BENEFITS

In applications where electric power is more economically available than fossil fuels, or where fossil fuel combustion and the handling of combustion by-products are unacceptable, electric boilers offer a viable alternative.

Compact Design

Electric boilers are typically one-quarter to one-half the size of fuel fired boilers with similar BTU per hour output. The smaller footprint reduces the overall boiler room space.

No Stack Requirements

With no products of combustion to contend with, installation costs are reduced by the elimination of stack requirements. This means the unit can be located anywhere in the building and the exterior of the building is not compromised with an unsightly stack, particularly helpful in tall or high rise buildings.

Emissions

Because there is no combustion, electric boilers are 100% emission free. This is beneficial in meeting total emissions of the project site or in areas where fuel combustion emissions are not tolerated.

Quiet Operation

Elimination of combustion noise and minimal moving parts results in extremely quiet operation, virtually no noise emissions. Very beneficial in applications such as hospitals, nursing homes, schools, and the like.

High Efficiency

With minimum radiation losses and not having the losses associated with combustion equipment the electric boiler will provide nearly 100% efficiency at all operating points.

Ease of Maintenance

The absence of high maintenance combustion equipment and the use of solid state control devices reduce the complexity and number of moving parts.

Electric elements are easily accessible and replaceable either individually or in flange mounted groups.

Pressure vessel components are not subjected to thermal stresses induced by high temperature differentials and cycling encountered with fossil fuel combustion.

Quality Construction

ISO 9001:2015 certified manufacturing process ensures the highest degree of manufacturing standards are always followed.

ASME Code construction ensures high quality design, safety, third party inspection, and reliability, and stamped accordingly.

Each unit is tested and certified in accordance with UL or cUL and the Label is affixed attesting to meeting the latest UL requirements for packaged electric boilers.

Progressive Sequencing Modulation

By individually controlling the heating elements with solid state digital step controllers, only the amount of heat required by system demand is generated. Virtually unlimited input control is available

with optional solid state analog current controllers, resulting in reduced on/off cycling, excellent load tracking, and reduced operating costs.

Designed For Heating Applications

Electric boilers are able to withstand virtually any return water temperature. With combustion by-products and high temperature differentials eliminated, condensation and thermal shock do not limit return water temperatures.

Because of the design characteristics, the electric boiler is well suited for applications utilizing indoor/outdoor reset controls, radiant floor heating, snow melt systems, and ground source heat pump systems

PRODUCT OFFERING

Information in this section applies to electric resistance steam or hot water boiler sizes ranging from 12 kW through 3375 kW for operation on 208, 240, 380, 415, 480 or 600 volts, three phase power supplies. Installation is for indoor use only.

The complete package has been tested and certified in accordance with U.L. and is approved, listed, and bears the U.L. label (U.S.A. and Canada) for electric resistance boilers. For Canada, each vessel is registered in each Province and the relative CRN number is attached to the boiler.

Dimensions, ratings, and product information may change to meet current market requirements and product improvements. Therefore, use this information as a guide.

Refer to Table 1 as a quick reference guide to the boiler models and sizes provided.

Standard Equipment - Steam Boilers

Equipment described below is for the standard steam electric boilers offering:

A. Model CR and S Boiler

1. Each boiler is designed and constructed in accordance with the A.S.M.E. Code; UL listed, and are mounted on an integral steel frame. Fiberglass insulation (2" thickness) is covered with a preformed, sectional steel painted jacket, factory installed.
2. Trim and Controls:
 - a. Manual Reset High Pressure Cutoff.
 - b. Probe Aux. Low Water Cutoff, MR.
 - c. Aux. Auto High Pressure Cutoff.
 - d. For S/CR models:
 - 1-Step: (1) on/off pressure switch.
 - 2-Step: (2) on/off pressure switch.
 - 3-Step+: Digital PID pressure control with progressive step control with adjustable span and inter-stage time delay.
 - e. Primary Low Water Cutoff and On/Off Pump Controller.
 - f. Bottom and Water Column Blowdown Valves.
 - g. Feedwater Stop and Check Valves.
 - h. A.S.M.E Pressure Relief Valve(s).
 - i. Steam Pressure Gauge w/test cock.
 - j. Sight Gauge with drain and guards.
3. Model CR Boilers include an integral Feedwater Tank and Feedwater Pump Assembly piped and wired.

4. Electric Equipment
 - a. Main Control Panel.
 - b. Lugs for the primary power supply, top of panel ingress as standard.
 - c. Fuses for each contactor, 200,000 Amps interrupting capacity (AIC).
 - d. Contactors duty rated @ 500,000 cycles.
 - e. Pilot lights for "Control Power On", "High Pressure", "Low Water", and "Steps".
 - f. 67 watts per square inch (WSI) Incoloy 800 heating elements.
 - g. Control Circuit Step-down Transformer with primary and secondary fuses and secondary control power switch.
 - h. Terminal strip for control wiring and external customer connections.
5. Vessel Inspection Openings:
 - S/CR120 to S/CR 162: Element Flange.
 - S/CR200 to S/CR302: 3" Half Coupling.
 - S361 and larger: 12" x 16" Manway.

B. Model HSB Boiler

1. Each boiler is designed and constructed in accordance with the A.S.M.E. Code; UL listed, and are mounted on an integral steel frame. Fiberglass insulation (2" thickness) is covered with a preformed, sectional steel painted jacket, factory installed.
2. Trim and Controls:
 - a. Manual Reset High Pressure Cutoff.
 - b. Probe Aux. Low Water Cutoff, MR.
 - c. Aux. Auto High Pressure Cutoff.
 - d. Digital PID pressure control with progressive step control with adjustable span and inter-stage time delay.
 - e. Primary Low Water Cutoff and On/Off Pump Controller.
 - f. Bottom and Water Column Blowdown Valves.
 - g. Feedwater Stop and Check Valves.
 - h. A.S.M.E Pressure Relief Valve(s).
 - i. Steam Pressure Gauge w/test cock.
 - j. Sight Gauge with drain and guards.
3. Electric Equipment
 - a. Main Control Panel with panel door key lock.
 - b. Lugs for the primary power supply, top of panel ingress as standard.
 - c. Fuses for each contactor, 200,000 Amps interrupting capacity (AIC).
 - d. Contactors duty rated @ 500,000 cycles.
 - e. Pilot lights for "Control Power On", "High Pressure", "Low Water", and "Steps".
 - f. 75 watts per square inch (WSI) "Incoloy- 800" heating elements.
 - g. Control Circuit Step-down Transformer with primary and secondary fuses and secondary control power switch.
 - h. Terminal strip for control wiring and external customer connections.
4. Vessel Inspection Openings:
 - HSB-423 and larger: 12" x 16" Manway.

Standard Equipment - Water Boilers

Equipment described below is for the standard hot water electric boilers offering:

A. Model WB Boiler

1. The Model WB boiler is designed and constructed in accordance with the A.S.M.E. Code; UL listed, and are mounted on an integral steel frame. Fiberglass insulation (2" thickness) is covered with a preformed, sectional steel painted jacket, factory installed.
2. Trim and Controls:
 - a. Manual Reset High Temperature Cutoff.
 - b. Probe Low Water Cutoff, auto reset.
 - c. Aux. Auto High Temperature Cutoff.
 - d. For WB models:
 - 1-Step: (1) on/off temperature switch.
 - 2-Step: (2) on/off temperature switch.
 - 3-Step+: Digital PID temperature control with progressive step control with adjustable span and inter-stage time delay.
 - e. Bottom drain valve.
 - f. A.S.M.E Pressure Relief Valve(s).
 - g. WB models with 1-2 steps: Separate Pressure and temperature gauge.
 - h. WB models with 3 or more steps: Separate Pressure Gauge and Digital Temperature Readout.
3. Electric Equipment
 - a. Main Control Panel.
 - b. Lugs for the primary power supply, top of panel ingress as standard.
 - c. Fuses for each contactor, 200,000 Amps interrupting capacity (AIC).
 - d. Contactors duty rated @ 500,000 cycles.
 - e. Pilot lights for "Control Power On", "High Pressure", "Low Water", and "Steps".
 - f. 75 watts per square inch (WSI) "Incoloy- 800" heating elements.
 - g. Control Circuit Step-down Transformer with primary and secondary fuses and secondary control power switch.
 - h. Terminal strip for control wiring and external customer connections.
4. Vessel Inspection Openings:
 - WB-120 to WB-122: Element Flange.
 - WB-201 to WB-243: 3" Half Coupling.
 - WB-361 and larger: 12" x 16" Manway.

Optional Equipment

For option details, contact the local authorized Cleaver-Brooks representative. Available options include the following:

- Output step enable/disable toggle switches.
- Additional Pilot Lights.
- Alarm relays for remote annunciation.
- Alarm Horn with silence switch.
- Safety Door Interlock.
- Outdoor reset control.
- Time Clock.
- Ammeter.
- Voltmeter.
- Kilowatt hour meter.
- Ground Fault Detection.
- Pneumatic control interface (3-15 or 6 - 30 psig to 0 - 145 ohms.)
- Load limiting module.
- Auxiliary Low Water Cutoff.
- Preheat Switch for elements.
- Manual Disconnect Switches.
- Shunt Trip for disconnect switches.
- Main Power Door Interlock (standard with switchgear below 600 AMPS).
- Blowdown Separators.
- Water Softener.
- Chemical Feed Systems.
- SCR controls
- Local/Remote control
- BMS interface
- Return water baffle
- Conductivity control

Optional choices also available for nozzles, inspection hand holes, and valves.

Table 1. Standard Product Offering

Product Type	Boiler Model	Output (kW)	Element Density (W/sq in)	Water Content (gallons)	Design Pressure (psig)	Notes
Hot water boilers	WB	12 - 3360	75 or 78@380V/415V	16 - 500	160, 200, 250 ^A	1
Steam boilers	S	12 - 2250	67 or 78@380V/415V/600V	16 - 595	15, 150, 200, 250	1
	CR	12 - 563	67 or 78@380V/415V/600V	16 - 115	15, 150, 200, 250	1, 2
	HSB	1560 - 3375	75 or 78@380V/415V/600V	180 - 790	15, 150, 200, 250	1

Notes: 1. Heating elements are of Incolloy-800 construction

2. Model CR identical to Model S but has integral condensate return tank and pump.

A. Model WB design pressure above 160 psig voids UL label.

DIMENSIONS AND RATINGS

For layout purposes, the overall dimensions for the Electric Boilers are shown in **Figures 1 through 4** including the various pipe connections sizes for supply and return water, drain, and steam supply.

Specific ratings of each model are noted in **Tables 2 through 11**. These tables provide the ampacity at the various supply voltages, element ratings, and contactors employed in the standard models.

Altitude

Because the electric boiler does not require combustion air, installation of the boiler at any elevation is possible without derating or providing special devices for altitude correction normally associated with fuel combustion. Thus the ratings shown are for all elevations.

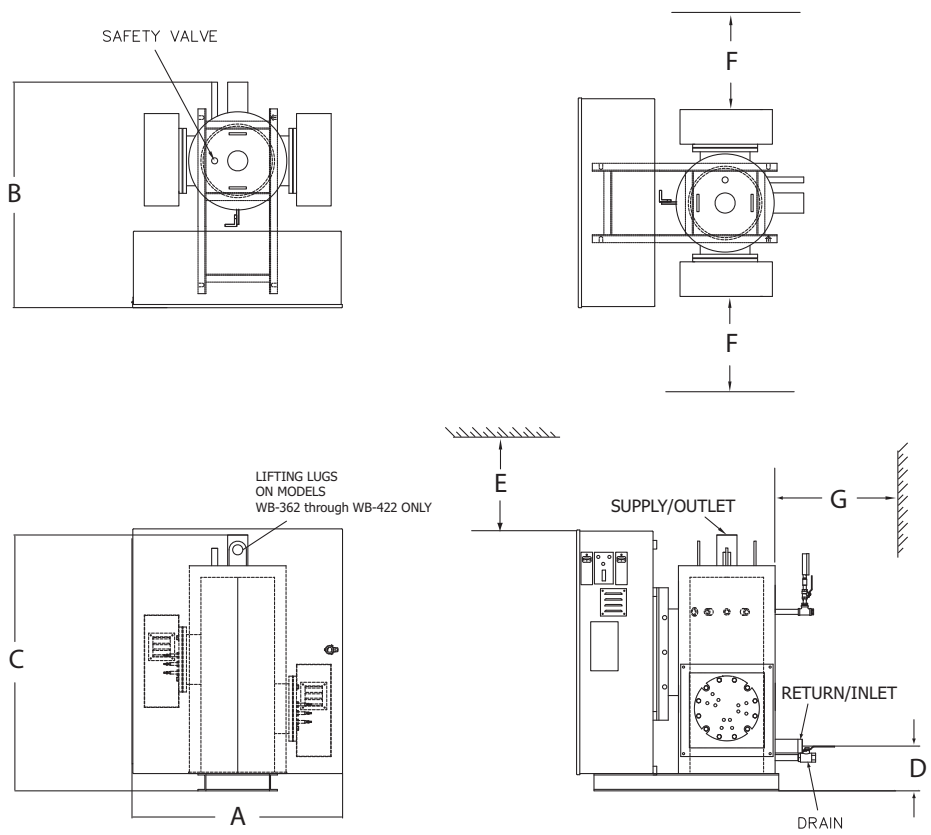

MODEL NO	CONNECTION SIZE (NPT)			DIMENSIONS (IN.)				CLEARANCES			APPROXIMATE WEIGHTS (LBS.)	
				WIDTH	DEPTH	HEIGHT [†]	INLET	TOP	SIDES	REAR	SHIPPING	OPERATING
	SUPPLY	RETURN	DRAIN	A	B	C	D	E	F	G		
WB-120 ^{††}	2	2	3/4	28	34	50	8	12	16	12	450	580
WB-121 ^{††}	3	3	3/4	32	34	50	8	12	16	12	500	630
WB-122 ^{††}	3	3	3/4	36	34	68	8	12	16	12	800	1005
WB-201 ^{††}	4 *	4 *	1-1/4	52	47	80	19	18	16	18	1400	2040
WB-202 ^{††}	4 *	4 *	1-1/4	52	47	90	19	18	16	18	1500	2140
WB-241 ^{††}	6 *	6 *	1-1/2	48	58	81	19	18	25	18	2200	3200
WB-242 ^{††}	6 *	6 *	1-1/2	60	58	89	19	18	25	18	2400	3400
WB-243 ^{††}	6 *	6 *	1-1/2	72	58	97	19	18	25	18	2800	3980
WB-361	6 *	6 *	1-1/2	72	70	97	24	24	30	24	3300	5260
WB-362	8 *	8 *	1-1/2	72	72	109	24	24	30	24	3600	6220
WB-363	8 *	8 *	2	112	72	117	24	24	30	36	4200	7280
WB-421	10 *	10 *	2	112	78	103	24	24	33	36	5800	9300
WB-422	10 *	10 *	2	112	78	114	24	24	33	36	6500	10500

NOTES: [†]Dimensional heights are for the boiler only. Control panel size varies based on the number of steps and optional equipment.

^{††}Lifting lugs are not provided; boiler shall be skid-mounted.

*These are flange connections; 150# ANSI.

Figure 1. Model WB Dimensions

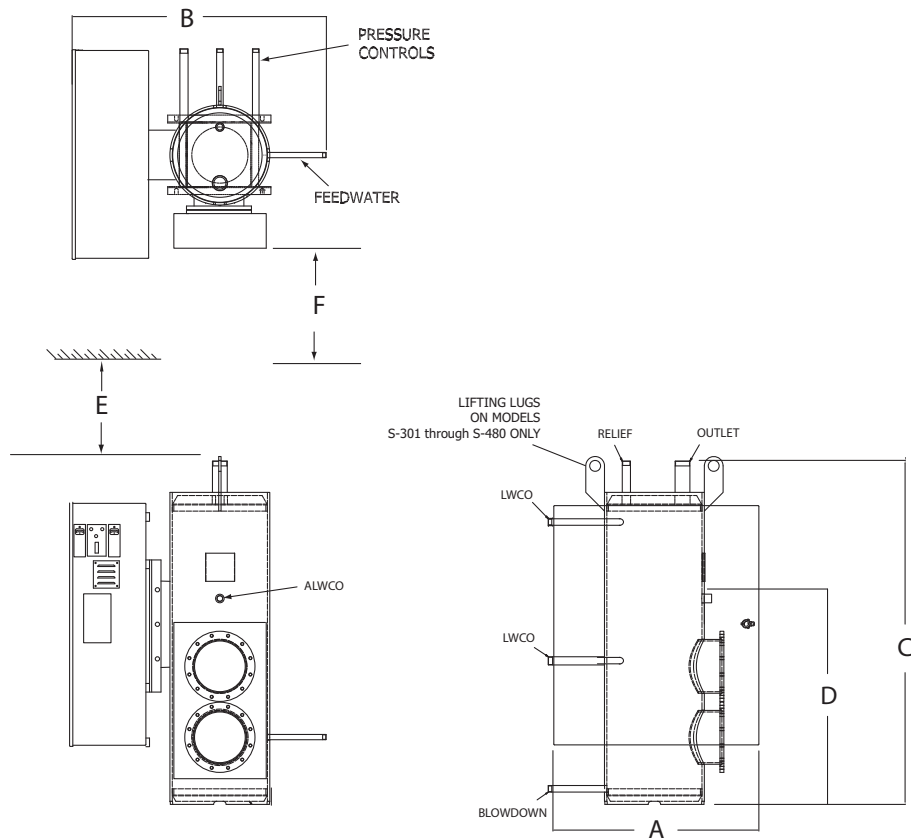

MODEL NO	CONNECTION SIZE (NPT)			DIMENSIONS (IN.)				CLEARANCES		APPROXIMATE WEIGHTS (LBS.)	
	BLOWDOWN		FEED-WATER	WIDTH	DEPTH	HEIGHT†	LWCO	TOP	SIDES	SHIPPING	OPERATING
	15 PSIG	150 PSIG		A	B	C	D	E	F		
S-120††	3/4	3/4	1/2	38	38	58	18	12	16	600	675
S-161††	3/4	3/4	1/2	44	42	69	35	12	20	750	880
S-162††	3/4	3/4	1/2	44	42	69	35	12	20	800	930
S-200††	1	1	3/4	46	47	76	42	12	20	1150	1480
S-241††	1-1/4	1	3/4	43	58	78	42	12	20	1400	1900
S-242††	1-1/4	1	3/4	43	58	78	42	12	20	1600	2000
S-301	1-1/2	1	3/4	49	62	94	50	15	20	2100	3000
S-302	1-1/2	1	3/4	49	66	94	50	15	20	2200	3300
S-361	1-1/2	1	3/4	56	72	79	41	18	36	2900	4000
S-362	1-1/2	1	3/4	56	78	94	52	18	36	3200	4800
S-421	1-1/2	1	1	62	84	82	44	18	36	4150	5800
S-422	1-1/2	1	1	62	84	94	52	18	36	4500	6700
S-480	2	1-1/4	1	72	90	104	52	18	36	5450	8000

NOTES: †Dimensional heights are for the boiler only. Control Panel size varies based on the number of steps and optional equipment.

††Lifting lugs are not provided; boiler shall be skid-mounted.

Figure 2. Model S Dimensions

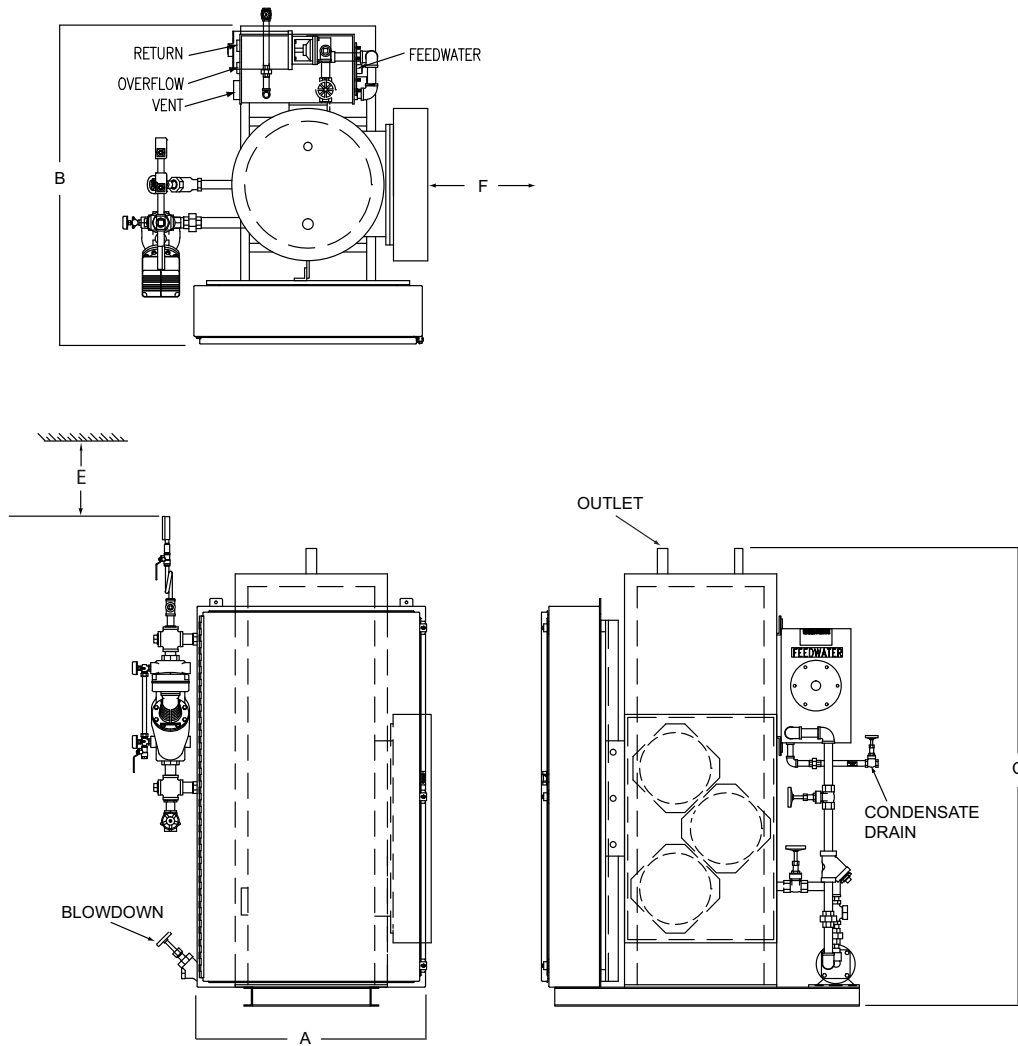

MODEL NO	CONNECTION SIZE (NPT)							DIMENSIONS (IN.)				CLEARANCES		APPROX. WEIGHTS (LBS.)	
	BLOWDOWN		COND. RETURN	OVERFLOW	VENT	FEED-WATER	DRAIN	WIDTH	DEPTH	HEIGHT†	LWCO	TOP	SIDES	SHIPPING	OPERATING
	15 PSIG	150 PSIG						A	B	C	D	E	F		
CR-120	3/4	3/4	1	1	2	3/4	1/2	40	46	58	18	12	16	850	950
CR-161	3/4	3/4	1	1	2	3/4	1/2	44	50	69	35	12	20	1050	1200
CR-162	3/4	3/4	1	1	2	3/4	1/2	44	50	69	35	12	20	1150	1280
CR-200	1	1	1	1	2	3/4	1/2	48	54	76	42	12	20	1650	2030
CR-241	1-1/4	1	1	1	2	3/4	1/2	43	58	78	42	12	20	2000	2600
CR-242	1-1/4	1	1	1	2	3/4	1/2	43	58	78	42	12	20	2200	2700

NOTES† Dimensional heights are for the boiler only. Control Panel size varies based on the number of steps and optional equipment.

Figure 3. Model CR Dimensions

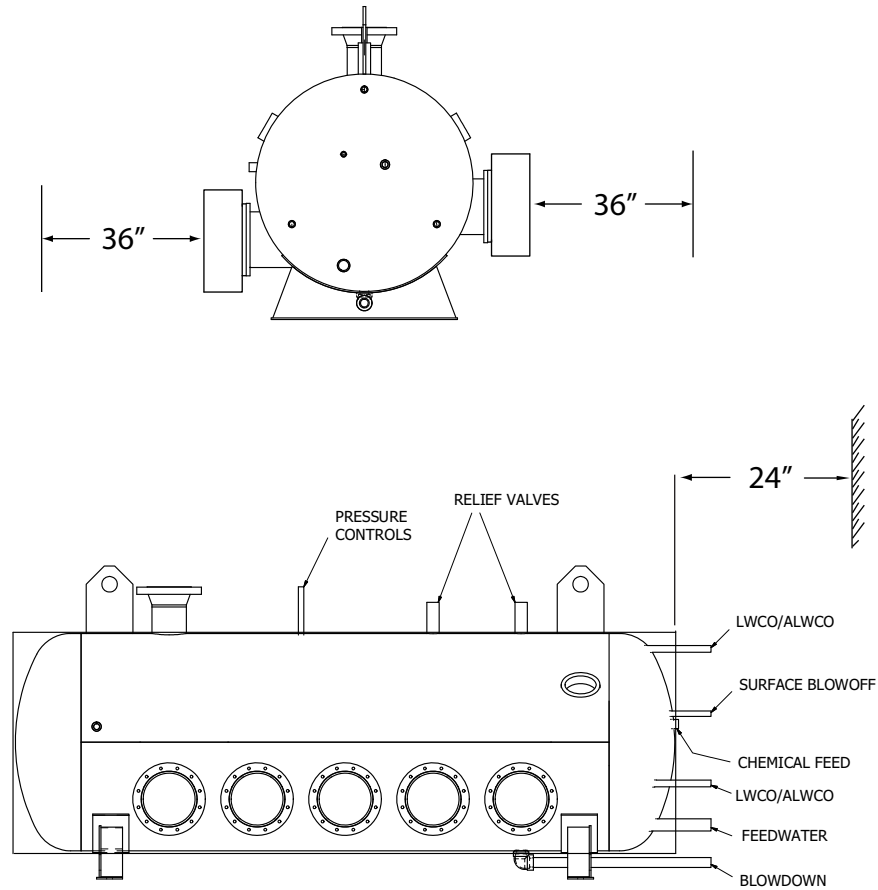

MODEL NO	CONNECTION SIZE (NPT)			DIMENSIONS (IN.)				CLEARANCES		APPROXIMATE WEIGHTS (LBS.)	
	BLOWDOWN		FEED-WATER	WIDTH	DEPTH	HEIGHT	LWCO	TOP	SIDES	SHIPPING	OPERATING
	15 PSIG	150 PSIG		A	B	C	D	E	F		
HSB-423	2	1-1/2	1	155	70	72	34	24	36	5700	8000
HSB-424	2	1-1/2	1	172	72	72	34	24	36	6400	9300
HSB-425	2	1-1/2	1	189	72	72	34	24	36	7100	10600

NOTES: Dimensional heights are for the boiler only. Control Panel size varies based on the number of steps and optional equipment.

Figure 4. Model HSB Dimensions

Table 2. Model WB Ratings 208V, 240V Supplies

MODEL	Vessel Capacity (gallons)	Rated kW	MBTU/HR	ELEMENTS		# of CONTACTORS	NUMBER and kW of STEPS	3-PHASE AMPERES	
				Qty	kW			208V	240V
WB-120	16	12	41	3	4	1	1@12	34	30
		18	61	3	6	1	1@18	51	44
		24	82	6	4	2	1@24	68	59
		30	102	6	5	2	1@30	84	73
		36	123	6	6	2	1@36	101	87
		45	154	9	5	3	1@30,1@15	126	109
		54	184	9	6	3	1@36,1@18	151	131
		60	205	12	5	4	2@30	167	145
WB-121	16	72	246	12	6	4	2@36	201	174
		90	307	15	6	5	2@36,1@18	251	217
		108	368	18	6	6	3@36	301	261
		126	430	21	6	7	3@36,1@18	351	304
WB-122	25	144	491	24	6	8	4@36	401	347
		162	553	27	6	9	4@36,1@18	451	391
		180	614	30	6	10	5@36	501	434
		198	676	33	6	11	5@36,1@18	551	477
		216	737	36	6	12	6@36	601	521
		234	798	39	6	13	6@36,1@18	651	564
		252	860	42	6	14	7@36	701	607
		270	921	45	6	15	7@36,1@18	751	651
WB-201	78	288	983	48	6	16	8@36	801	694
		324	1105	54	6	18	6@54	901	781
		360	1228	60	6	20	4@54,4@36	1001	868
		396	1350	66	6	22	6@54,2@36	1101	954
		432	1474	72	6	24	8@54	1201	1041

Table 3. Model WB Ratings 380V, 415V Supplies

MODEL	Vessel Capacity (gallons)	Rated kW	MBTU/HR	ELEMENTS		# of CONTACTORS	NUMBER and kW of STEPS	3-PHASE AMPERES	
				Qty	kW	380/415V	380/415V	380V	415V
WB-120	16	15	51	3	5	1	1@15	23	21
		30	102	6	5	1	1@30	46	42
		45	154	9	5	2	1@15, 1@30	68	63
		60	205	12	5	2	2@30	91	83
WB-121	16	75	256	15	5	3	1@15, 2@30	114	104
		90	307	18	5	3	3@30	137	125
		105	358	21	5	4	1@15, 3@30	160	146
		120	409	24	5	4	4@30	182	167
WB-122	25	135	461	27	5	5	1@15, 4@30	205	188
		150	512	30	5	5	5@30	228	209
		165	563	33	5	6	1@15, 5@30	251	230
		180	614	36	5	6	6@30	273	250
		195	665	39	5	7	1@15, 6@30	296	271
		210	717	42	5	7	7@30	319	292
		225	768	45	5	8	1@15, 7@30	342	313
WB-201	78	270	921	54	5	9	7@30, 1@60	410	376
		300	1024	60	5	10	6@30, 2@60	456	417
		330	1126	66	5	11	5@30, 3@60	501	459
		360	1228	72	5	12	4@30, 4@60	547	501
WB-202	78	390	1331	78	5	13	3@30, 5@60	593	543
		420	1433	84	5	14	2@30, 6@60	638	584
		450	1535	90	5	15	1@30, 7@60	684	626
		480	1638	96	5	16	8@60	729	668
WB-241	122	510	1740	51	10	17	3@30, 7@60	775	710
		540	1842	54	10	18	2@30, 8@60	820	751
		570	1945	57	10	19	1@30, 9@60	866	793
		600	2047	60	10	20	10@60	912	835
		630	2150	63	10	21	3@30, 9@60	957	876
		660	2252	66	10	22	2@30, 10@60	1003	918
		690	2354	69	10	23	1@30, 11@60	1048	960
WB-242	122	720	2457	72	10	24	12@60	1094	1002
		750	2559	75	10	25	11@60, 1@90	1140	1043
		780	2661	78	10	26	10@60, 2@90	1185	1085
		810	2764	81	10	27	9@60, 3@90	1231	1127
		840	2866	84	10	28	8@60, 4@90	1276	1169
		870	2968	87	10	29	7@60, 5@90	1322	1210
		900	3071	90	10	30	6@60, 6@90	1367	1252
		930	3173	93	10	31	5@60, 7@90	1413	1294
	960	3276	96	10	32	4@60, 8@90	1459	1336	

Table 3. Model WB Ratings 380V, 415V Supplies (Continued)

MODEL	Vessel Capacity (gallons)	Rated kW	MBTU/HR	ELEMENTS		# of CONTACTORS 380/415V	NUMBER and kW of STEPS 380/415V	3-PHASE AMPERES	
				Qty	kW			380V	415V
WB-243	142	990	3378	99	10	33	3@60, 9@90	1504	1377
		1020	3480	102	10	34	2@60, 10@90	1550	1419
		1050	3583	105	10	35	1@60, 11@90	1595	1461
		1080	3685	108	10	36	12@90	1641	1503
		1110	3787	111	10	37	5@60, 9@90	1687	1544
		1140	3890	114	10	38	4@60, 10@90	1732	1586
		1170	3992	117	10	39	3@60, 11@90	1778	1628
		1200	4094	120	10	40	2@60, 12@90	1823	1669
WB-362	315	1230	4197	123	10	41	1@60, 13@90	1869	1711
		1260	4299	126	10	42	14@90	1914	1753
		1290	4401	129	10	43	5@60, 11@90	1960	1795
		1320	4504	132	10	44	4@60, 12@90	2006	1836
		1350	4606	135	10	45	3@60, 13@90	2051	1878
		1380	4709	138	10	46	2@60, 14@90	2097	1920
		1410	4811	141	10	47	1@60, 15@90	2142	1962
		1440	4913	144	10	48	16@90	2188	2003
WB-363	370	1470	5016	147	10	49	5@60, 13@90	2233	2045
		1500	5118	150	10	50	4@60, 14@90	2279	2087
		1530	5220	153	10	51	3@60, 15@90	2325	2141
		1560	5323	156	10	52	2@60, 16@90	2370	2170
		1590	5425	159	10	53	1@60, 17@90	2416	2212
		1620	5527	162	10	54	18@90	2461	2254
		1650	5630	165	10	55	17@90, 1@120	2507	2296
		1680	5732	168	10	56	16@90, 2@120	2553	2337
		1710	5835	171	10	57	15@90, 3@120	2598	2379
		1740	5967	174	10	58	14@90, 4@120	2644	2421
		1770	6039	177	10	59	13@90, 5@120	2689	2463
		1800	6142	180	10	60	12@90, 6@120	2735	2504
WB-421	425	1830	6244	183	10	61	11@90, 7@120	2780	2546
		1860	6346	186	10	62	10@90, 8@120	2826	2588
		1890	6449	189	10	63	9@90, 9@120	2872	2629
		1920	6551	192	10	64	8@90, 10@120	2917	2671
		1950	6653	195	10	65	7@90, 11@120	2963	2713
		1980	6756	198	10	66	6@90, 12@120	3008	2755

Table 3. Model WB Ratings 380V, 415V Supplies (Continued)

MODEL	Vessel Capacity (gallons)	Rated kW	MBTU/HR	ELEMENTS		# of CONTACTORS 380/415V	NUMBER and kW of STEPS 380/415V	3-PHASE AMPERES	
				Qty	kW			380V	415V
WB-422	500	2010	6858	201	10	67	5@90, 13@120	3054	2796
		2040	6960	204	10	68	4@90, 14@120	3100	2838
		2070	7063	207	10	69	3@90, 15@120	3145	2880
		2100	7165	210	10	70	2@90, 16@120	3191	2922
		2130	7268	213	10	71	1@90, 17@120	3236	2963
		2160	7370	216	10	72	18@120	3282	3005
		2190	7472	219	10	73	23@90, 1@120	3327	3047
		2220	7575	222	10	74	22@90, 2@120	3373	3089
		2250	7677	225	10	75	21@90, 3@120	3419	3130
		2280	7779	228	10	76	20@90, 4@120	3464	3172
		2310	7882	231	10	77	19@90, 5@120	3510	3214
		2340	7984	234	10	78	18@90, 6@120	3555	3256
		2370	8086	237	10	79	17@90, 7@120	3601	3297
		2400	8189	240	10	80	16@90, 8@120	3647	3339
		2430	8291	243	10	81	15@90, 9@120	3692	3381
		2460	8394	246	10	82	14@90, 10@120	3738	3422
2490	8496	249	10	83	13@90, 11@120	3783	3464		
2520	8598	252	10	84	12@90, 12@120	3829	3506		

Table 4. Model WB Ratings 480V, 600V Supplies

Model	Vessel Capacity (gallons)	Rated kW	MBTU/HR	ELEMENTS		# of CONTACTORS 480/600V	NUMBER and kW of STEPS 480/600V	3-PHASE AMPERES	
				Qty	kW			480V	600V
WB-120	16	12	41	3	4	1	1 @ 12	15	13
		18	61	3	6	1	1 @ 18	22	18
		24	82	6	4	1	1 @ 24	30	24
		30	102	6	5	1	1 @ 30	37	29
		36	123	6	6	1	1 @ 36	44	35
		45	154	9	5	2	1 @ 45	55	44
		54	184	9	6	2	1 @ 54	66	53
		60	205	12	5	2	2 @ 30	73	58
WB-121	16	72	246	12	6	2	2 @ 36	87	70
		90	307	15	6	3	2 @ 36, 1 @18	109	87
		108	368	18	6	3	3 @ 36	131	105
		126	430	21	6	4	3 @36, 1 @18	152	122
WB-122	25	144	491	24	6	4	4 @ 36	174	139
		162	553	27	6	5	3 @36, 1 @54	196	157
		180	614	30	6	5	5 @ 36	217	174
		198	676	33	6	6	5 @36, 1@18	239	191
		216	737	36	6	6	6 @ 36	261	209
		234	798	39	6	7	6 @36, 1 @18	282	226
		252	860	42	6	7	7 @ 36	304	243
		270	921	45	6	8	7 @36, 1 @18	326	261
WB-201	78	288	983	48	6	8	8 @ 36	347	278
		324	1105	54	6	9	3 @72, 3 @36	391	313
		360	1228	60	6	10	2 @72, 6 @36	434	347
		396	1350	66	6	11	3 @72, 5 @36	477	382
WB-202	78	432	1474	72	6	12	4 @72, 4 @36	521	417
		468	1597	78	6	13	5 @72, 3 @36	564	451
		504	1720	84	6	14	6 @72, 2 @36	607	486
		540	1842	90	6	15	7 @72, 1 @36	651	521
WB-241	122	576	1965	96	6	16	8 @72	694	555
		600	2047	60	10	20	10 @ 60	723	579
		630	2150	63	10	21	3 @30, 9 @60	759	607
		660	2252	66	10	22	2 @30, 10 @60	795	636
		690	2354	69	10	23	1@30, 11 @60	831	665
		720	2457	72	10	24	12 @60	868	694
WB-242	122	750	2559	75	10	25	5 @90, 5 @60	904	723
		780	2661	78	10	26	6 @90, 4 @60	940	752
		810	2764	81	10	27	7 @90, 3 @60	976	781
		840	2866	84	10	28	8 @90, 2 @60	1012	810
		870	2968	87	10	29	9 @90, 1 @60	1048	838
		900	3071	90	10	30	10 @ 90	1084	868
		930	3173	93	10	31	7 @90, 5 @60	1120	896
		960	3276	96	10	32	8 @90, 4 @60	1157	925
WB-243	142	990	3378	99	10	33	9 @90, 3 @60	1193	954
		1020	3480	102	10	34	10 @90, 2 @60	1229	983
		1050	3583	105	10	35	11 @90, 1 @60	1265	1012
		1080	3685	108	10	36	12 @ 90	1301	1041
		1110	3787	111	10	37	9 @90, 5 @60	1337	1070
		1140	3890	114	10	38	10 @90, 4 @60	1373	1099
		1170	3992	117	10	39	11 @90, 3 @60	1409	1128
		1200	4094	120	10	40	12 @90, 2 @60	1446	1157
WB-361	235	1224	4176	102	12	34	10 @108, 2 @72	1474	1180
		1260	4299	105	12	35	11 @108, 1 @72	1518	1214
		1296	4422	108	12	36	12 @ 108	1561	1249

Table 4. Model WB Ratings 480V, 600V Supplies (Continued)

Model	Vessel Capacity (gallons)	Rated kW	MBTU/HR	ELEMENTS		# of CONTACTORS 480/600V	NUMBER and kW of STEPS 480/600V	3-PHASE AMPERES	
				Qty	kW			480V	600V
WB-362	315	1332	4545	111	12	37	9 @108, 5 @72	1605	1284
		1368	4668	114	12	38	10 @108, 4 @72	1648	1318
		1404	4790	117	12	39	11 @108, 3 @72	1691	1353
		1440	4913	120	12	40	12 @108, 2 @72	1735	1388
		1476	5036	123	12	41	13 @108, 1 @72	1778	1422
		1512	5159	126	12	42	14 @ 108	1821	1457
		1548	5282	129	12	43	11 @108, 5 @72	1865	1492
		1584	5405	132	12	44	12 @108, 4 @72	1908	1527
		1620	5527	135	12	45	13 @108, 3 @72	1951	1561
		1656	5650	138	12	46	14 @108, 2 @72	1995	1596
1692	5773	141	12	47	15 @108, 1 @72	2038	1631		
	1728	5896	144	12	48	16 @ 108	2081	1665	
WB-363	370	1764	6019	147	12	49	13 @108, 5 @ 72	2125	1700
		1800	6142	150	12	50	14 @108, 4 @ 72	2168	1735
		1836	6264	153	12	51	15 @108, 3 @ 72	2211	1769
		1872	6387	156	12	52	16 @108, 2 @ 72	2255	1804
		1908	6510	159	12	53	17 @108, 1 @ 72	2298	1839
		1944	6633	162	12	54	18 @ 108	2342	1873
		1980	6756	165	12	55	15 @108, 5 @ 72	2385	1908
		2016	6879	168	12	56	16 @108, 4 @ 72	2428	1943
		2052	7001	171	12	57	17 @108, 3 @ 72	2472	1977
		2088	7124	174	12	58	18 @108, 2 @ 72	2515	2012
	2160	7370	180	12	60	20 @ 108	2602	2081	
WB-421	425	2240	7643	168	13.3	56	16 @120, 4 @ 80	2698	2158
		2320	7916	174	13.3	58	18 @ 120, 2 @ 80	2794	2236
		2400	8189	180	13.3	60	20 @ 120	2891	2313
		2480	8462	186	13.3	62	2 @160, 18 @120	2987	2390
		2560	8735	192	13.3	64	4 @160, 16 @120	3083	2467
		2640	9008	198	13.3	66	6 @160, 14 @120	3180	2544
WB-422	500	2720	9281	204	13.3	68	8 @160, 12 @120	3276	2621
		2800	9554	210	13.3	70	10 @160, 10 @120	3372	2698
		2880	9827	216	13.3	72	12 @160, 8 @120	3469	2775
		3000	10236	225	13.3	75	15 @160, 5 @120	3613	2891
		3040	10372	228	13.3	76	16 @160, 4 @120	3661	2929
		3120	10509	234	13.3	78	18 @160, 2 @120	3758	3006
		3200	10645	240	13.3	80	20 @ 160	3854	3083
		3280	11191	246	13.3	82	18 @160, 2 @200	3950	3160
	3360	11464	252	13.3	84	4 @200, 16 @160	4047	3237	

Table 5. Model S/CR Ratings 208V Supply

Model	Vessel Capacity (gallons)	Steam Space (gallons)	Rated kW	ASME (Steam lbs/hr)	ELEMENTS		# of CONTACTORS 208V	NUMBER and kW of STEPS	3-PHASE AMPERES
					Qty	kW		208V	208V
S/CR-120	9	7	9	31	3	3	1	1 @ 9	26
			18	63	6	3	2	1 @ 18	51
			27	94	9	3	3	1 @ 27	76
			36	126	12	3	4	2 @ 18	101
S/CR-161	23	16	45	158	9	5	3	1 @30, 1 @15	126
			60	211	12	5	4	2 @ 30	168
S/CR-162	23	16	75	263	15	5	5	2 @30, 1 @15	210
			90	316	18	5	6	3 @ 30	251
			105	369	21	5	7	3 @30, 1 @15	293
			120	422	24	5	8	4 @ 30	334
S/CR-200	48	26	135	474	27	5	9	4 @30, 1 @15	376
			150	527	30	5	10	5 @ 30	417
			165	580	33	5	11	5 @30, 1 @15	459
			180	633	36	5	12	6 @ 30	501
S/CR-241	62	53	195	685	39	5	13	6 @30, 1 @15	543
			210	738	42	5	14	7 @ 30	584
			225	791	45	5	15	7 @30, 1 @15	626
			240	844	48	5	16	8 @ 30	667
S/CR-242	62	53	255	896	51	5	17	1 @ 45, 7 @ 30	709
			270	949	54	5	18	2 @ 45, 6 @ 30	750
			285	1002	57	5	19	3 @ 45, 5 @ 30	792
			300	1055	60	5	20	4 @ 45, 4 @ 30	834

Table 6. Model S/CR Ratings 240V Supply

Model	Vessel Capacity (gallons)	Steam Space (gallons)	Rated kW	ASME (Steam lbs/hr)	ELEMENTS		# of CONTACTORS 240V	NUMBER and kW of STEPS 240V	3-PHASE AMPERES 240V
					Qty	kW			
S/CR-120	9	7	12	42	3	4	1	1 @ 12	34
			24	84	6	4	2	1 @ 24	68
			36	126	9	4	3	1 @ 36	101
			48	168	12	4	4	2 @ 24	134
S/CR-161	23	16	60	210	9	6.7	3	1 @40, 1 @20	168
			80	280	12	6.7	4	2 @ 40	223
S/CR-162	23	16	100	350	15	6.7	5	2 @40, 1 @20	279
			120	420	18	6.7	6	3 @ 40	334
			140	490	21	6.7	7	3 @ 40, 1 @ 20	390
			160	560	24	6.7	8	4 @ 40	445
S/CR-200	48	26	180	630	27	6.7	9	4 @40, 1 @20	501
			200	700	30	6.7	10	5 @ 40	556
			220	770	33	6.7	11	5 @40, 1 @ 20	612
			240	840	36	6.7	12	6 @ 40	667
S/CR-241	62	53	260	910	39	6.7	13	6 @40, 1 @ 20	723
			280	980	42	6.7	14	7 @ 40	778
			300	1050	45	6.7	15	7 @ 40, 1 @ 20	834
			320	1120	48	6.7	16	8 @ 40	889
S/CR-242	62	53	340	1190	51	6.7	17	1 @ 60, 7 @ 40	945
			360	1260	54	6.7	18	2 @ 60, 6 @ 40	1000
			380	1330	57	6.7	19	3 @ 60, 5 @ 40	1056
			400	1400	60	6.7	20	4 @ 60, 4 @ 40	1111

Table 7. Model S/CR Ratings 380V, 415V Supplies

Model	Vessel Capacity (gallons)	Steam Space (gallons)	Rating kW	ASME (Steam lbs/hr)	ELEMENTS		# of CONTACTORS 380V/415V	NUMBER and kW of STEPS 380V/415V	3-PHASE AMPERES	
					Qty	kW			380V	415V
S/CR-161	23	16	15	51	3	5	1	1 @ 15	23	21
			30	102	6	5	1	1@30	46	42
			45	154	9	5	2	1@15, 1@30	68	63
			60	205	12	5	2	2@30	91	83
S/CR-162	23	16	75	256	15	5	3	1@15, 2@30	114	104
			90	307	18	5	3	3@30	137	125
			105	358	21	5	4	1@15, 3@30	160	146
			120	409	24	5	4	4@30	182	167
S/CR-200	48	26	135	461	27	5	5	1@15, 4@30	205	188
			150	512	30	5	5	5@30	228	209
			165	563	33	5	6	1@15, 5@30	251	230
			180	614	36	5	6	6@30	273	250
S/CR-241	62	53	210	717	21	10	7	7@30	319	292
			240	819	24	10	8	8@30	365	334
S/CR-242	62	53	270	921	27	10	9	7@30, 1@60	410	376
			300	1024	30	10	10	6@30, 2@60	456	417
			330	1126	33	10	11	5@30, 3@60	501	459
			360	1228	36	10	12	4@30, 4@60	547	501
			390	1331	39	10	13	3@30, 5@60	593	543
			420	1433	42	10	14	2@30, 6@60	638	584
			450	1535	45	10	15	1@30, 7@60	684	626
			480	1638	48	10	16	8@60	729	668
S-301	110	53	510	1740	51	10	17	3@30, 7@60	775	710
			540	1842	54	10	18	2@30, 8@60	821	751
			570	1945	57	10	19	1@30, 9@60	866	793
			600	2047	60	10	20	10@60	912	835
			630	2150	63	10	21	3@30, 9@60	957	876
			660	2252	66	10	22	2@30, 10@60	1003	918
			690	2354	69	10	23	1@30, 11@60	1048	960
			720	2457	72	10	24	12@90	1094	1002
S-362	200	130	750	2559	75	10	25	11@60, 1@90	1140	1043
			780	2661	78	10	26	10@60, 2@90	1185	1085
			810	2764	81	10	27	9@60, 3@90	1231	1127
			840	2866	84	10	28	8@60, 4@90	1276	1169
			870	2968	87	10	29	7@60, 5@90	1322	1210
			900	3071	90	10	30	6@60, 6@90	1367	1252
			930	3173	93	10	31	5@60, 7@90	1413	1294
			960	3276	96	10	32	4@60, 8@90	1459	1336
			990	3378	99	10	33	3@60, 9@90	1504	1377
S-421	210	180	1020	3480	102	10	34	2@60, 10@90	1550	1419
			1050	3583	105	10	35	1@60, 11@90	1595	1461
			1080	3685	108	10	36	12@90	1641	1503
S-422	270	180	1110	3787	111	10	37	5@60, 9@90	1687	1544
			1140	3890	114	10	38	4@60, 10@90	1732	1586
			1170	3992	117	10	39	3@60, 11@90	1778	1628
			1200	4094	120	10	40	2@60, 12@90	1823	1669
			1230	4197	123	10	41	1@60, 13@90	1869	1711
			1260	4299	126	10	42	14@90	1914	1753
S-480	360	235	1290	4401	129	10	43	5@60, 11@90	1960	1795
			1320	4504	132	10	44	4@60, 12@90	2006	1836
			1350	4606	135	10	45	3@60, 13@90	2051	1878
			1380	4709	138	10	46	2@60, 14@90	2097	1920
			1410	4811	141	10	47	1@60, 15@90	2142	1962
			1440	4913	144	10	48	16@90	2188	2003
			1470	5016	147	10	49	5@60, 13@90	2233	2045
			1500	5118	150	10	50	4@60, 14@90	2279	2087
			1530	5220	153	10	51	3@60, 15@90	2325	2129
			1560	5323	156	10	52	2@60, 16@90	2370	2170
			1590	5425	159	10	53	1@60, 17@90	2416	2212
			1620	5527	162	10	54	18@90	2461	2254

Table 8. Model S/CR Ratings 480V Supply

Model	Vessel Capacity (gallons)	Steam Space (gallons)	Rated kW	ASME (Steam lbs/hr)	ELEMENTS		# of CONTACTORS	NUMBER and kW of STEPS		3-PHASE AMPERES
					Qty	kW		480V	480V	480V
S/CR-120	9	7	12	42	3	4	1	1 @ 12	15	
			24	84	6	4	1	1 @ 24	29	
			36	126	9	4	1	1 @ 36	44	
			48	168	12	4	2	2 @ 24	58	
S/CR-161	23	16	60	210	9	6.7	2	1 @40, 1 @20	73	
			80	280	12	6.7	2	2 @ 40	97	
S/CR-162	23	16	100	350	15	6.7	3	2 @40, 1 @20	121	
			120	420	18	6.7	3	3 @ 40	145	
			140	490	21	6.7	4	3 @40, 1 @20	169	
			160	560	24	6.7	4	4 @ 40	193	
S/CR-200	48	26	180	630	27	6.7	5	4 @40, 1 @20	217	
			200	700	30	6.7	5	5 @ 40	241	
			220	770	33	6.7	6	5 @40, 1 @20	265	
			240	840	36	6.7	6	6 @ 40	289	
S/CR-241	62	53	260	910	39	6.7	7	6 @40, 1 @20	314	
			280	980	42	6.7	7	7 @ 40	338	
			300	1050	45	6.7	8	7 @40, 1 @20	362	
			320	1120	48	6.7	8	8 @ 40	386	
S/CR-242	62	53	340	1190	51	6.7	9	7 @40, 1 @60	410	
			360	1260	54	6.7	9	1 @80, 7 @40	434	
			380	1330	57	6.7	10	1@80,6@40,1@60	458	
			400	1400	60	6.7	10	2 @80, 6 @40	482	
			420	1470	63	6.7	11	2@80,5@40,1@60	506	
			440	1540	66	6.7	11	3 @80, 5 @40	530	
			460	1610	69	6.7	12	3@80,4@40,1@60	554	
			480	1680	72	6.7	12	4 @80, 4 @40	578	
S-302	140	90	500	1750	75	6.7	13	4 @80, 3 @40, 1@60	603	
			520	1820	78	6.7	13	5 @80, 3 @40	627	
			540	1890	81	6.7	14	5 @80, 2 @40, 1@60	651	
			560	1960	84	6.7	14	6 @80, 2 @40	675	
			580	2030	87	6.7	15	6 @80, 1 @40, 1@60	699	
			600	2100	90	6.7	15	7 @80, 1 @40	723	
			620	2170	93	6.7	16	7 @80, 1 @60	747	
			640	2240	96	6.7	16	8 @ 80	771	
			660	2310	99	6.7	17	6 @80, 3 @40, 1@60	795	
			680	2380	102	6.7	17	7 @80, 3 @40	819	
			700	2450	105	6.7	18	7 @80, 2 @40, 1@60	843	
			720	2520	108	6.7	18	8 @ 80, 2 @40	867	
S-361	150	100	756	2646	63	12	21	9 @72, 3 @36	911	
			792	2772	66	12	22	10 @72, 2 @36	954	
			828	2898	69	12	23	11 @72, 1 @36	998	
			864	3024	72	12	24	12 @ 72	1041	

Table 8. Model S/CR Ratings 480V Supply (Continued)

Model	Vessel Capacity (gallons)	Steam Space (gallons)	Rated kW	ASME (Steam lbs/hr)	ELEMENTS		# of CONTACTORS	NUMBER and kW of STEPS	3-PHASE AMPERES
					Qty	kW		480V	480V
S-362	200	130	900	3276	75	12	25	12 @72, 1 @36	1084
			936	3402	78	12	26	13 @ 72	1128
			972	3528	81	12	27	13 @72, 1 @36	1171
			1008	3780	84	12	28	14 @ 72	1214
S-421	210	140	1044	3654	87	12	29	14 @72, 1 @36	1258
			1080	3780	90	12	30	15 @ 72	1301
			1116	3906	93	12	31	15 @72, 1 @36	1344
			1152	4032	96	12	32	16 @ 72	1388
			1188	4158	99	12	33	16 @72, 1 @36	1431
			1224	4284	102	12	34	17 @ 72	1474
			1260	4410	105	12	35	17 @72, 1 @36	1518
1296	4536	108	12	36	18 @ 72	1560			
S-422	270	180	1332	4662	111	12	37	18 @ 72, 1 @36	1605
			1368	4788	114	12	38	19 @ 72	1648
			1404	4914	117	12	39	19 @ 72, 1 @36	1691
S-480	360	235	1440	5040	120	12	40	20 @ 72	1735
			1476	5166	123	12	41	9 @108, 7 @72	1778
			1512	5290	126	12	42	10 @108, 6 @72	1821
			1548	5418	129	12	43	11 @108, 5 @72	1864
			1584	5540	132	12	44	12 @108, 4 @72	1908
			1620	5670	135	12	45	13 @108, 3 @72	1951
			1656	5790	138	12	46	14 @108, 2 @72	1995
			1692	5922	141	12	47	15 @108, 1 @72	2038
			1728	6050	144	12	48	16 @ 108	2081
			1764	6174	147	12	49	13 @108, 5 @72	2125
			1800	6300	150	12	50	14 @108, 4 @72	2168
			1836	6426	153	12	51	15 @108, 3 @72	2211
			1872*	6552	156	12	52	16 @108, 2 @72	2255
			1908*	6678	159	12	53	17 @108, 1 @72	2298
1944*	6804	162	12	54	18 @108	2342			

* High pressure only

Table 9. Model S/CR Ratings 600V Supply

Model	Vessel Capacity (gallons)	Steam Space (gallons)	Rated kW	ASME (Steam lbs/hr)	ELEMENTS		# of CONTACTORS 600 V	NUMBER and kW of STEPS 600 V	3-PHASE AMPERES 600 V
					Qty	kW			
S/CR-120	9	7	19	66	3	6.3	1	1 @ 19	19
			38	131	6	6.3	1	1 @ 37	37
			56	197	9	6.3	2	1 @37, 1 @19	54
S/CR-161	23	16	70	246	9	7.8	2	1 @47, 1 @23	68
			75	263	12	6.3	2	2 @ 37	73
			94	328	12	7.8	2	2 @ 47	91
S/CR-162	23	16	117	410	15	7.8	3	2 @47, 1 @23	113
			141	492	18	7.8	3	3 @ 47	136
			164	574	21	7.8	4	3 @47, 1 @23	158
S/CR-200	48	26	188	656	24	7.8	4	4 @ 47	182
			211	738	27	7.8	5	4 @47, 1 @23	204
			234	820	30	7.8	5	5 @ 47	226
			258	902	33	7.8	6	5 @47, 1 @23	249
			281	984	36	7.8	6	6 @ 47	271
S/CR-241	62	53	305	1066	39	7.8	7	6 @47, 1 @23	294
			328	1148	42	7.8	7	7 @ 47	316
			352	1230	45	7.8	8	7 @47, 1 @23	340
			375	1313	48	7.8	8	8 @ 47	362
S/CR-242	62	53	398	1395	51	7.8	9	7 @47, 1 @70	384
			422	1477	54	7.8	9	1 @94, 7 @47	407
			445	1559	57	7.8	10	1 @94, 6 @47, 1@70	429
			469	1641	60	7.8	10	2 @94, 6 @47	452
			492	1724	63	7.8	11	2 @94, 5 @47, 1@70	474
			516	1805	66	7.8	11	3 @94, 5 @47	498
			539	1889	69	7.8	12	3 @94, 4 @47, 1@70	520
			563	1969	72	7.8	12	4 @94, 4 @47	543
S-302	140	90	586	2054	75	7.8	13	4 @94, 3 @47, 1@70	565
			609	2133	78	7.8	13	5 @94, 3 @47	587
			633	2218	81	7.8	14	5 @94, 2 @47, 1@70	610
			656	2297	84	7.8	14	6 @94, 2 @47	632
			672	2355	87	7.8	15	6 @94, 1 @47, 1@70	648
			703	2461	90	7.8	15	7 @94, 1 @47	678
S-361	150	100	750	2625	48	15.6	16	6 @94, 4 @47	723
			797	2789	51	15.6	17	7 @94, 3 @47	768
			844	2953	54	15.6	18	8 @94, 2 @47	814
			891	3117	57	15.6	19	9 @94, 1 @47	859
			938	3281	60	15.6	20	10 @ 94	904
			984	3445	63	15.6	21	9 @94 3 @47	948
			1031	3609	66	15.6	22	10 @94, 2 @47	994

Table 9. Model S/CR Ratings 600V Supply (Continued)

Model	Vessel Capacity (gallons)	Steam Space (gallons)	Rated kW	ASME (Steam lbs/hr)	ELEMENTS		# of CONTACTORS 600 V	NUMBER and kW of STEPS 600 V	3-PHASE AMPERES 600 V
					Qty	kW			
S-421	210	140	1078	3773	69	15.6	23	11 @94, 1 @47	1039
			1125	3938	72	15.6	24	12 @ 94	1084
			1172	4102	75	15.6	25	12 @94, 1 @47	1129
			1219	4266	78	15.6	26	13 @ 94	1175
			1266	4430	81	15.6	27	13 @94, 1 @47	1220
			1313	4594	84	15.6	28	14 @ 94	1265
			1359	4758	87	15.6	29	14 @94, 1 @47	1310
			1406	4922	90	15.6	30	15 @ 94	1355
			1453*	5086	93	15.6	31	15 @94, 1 @47	1400
			1500*	5250	96	15.6	32	16 @ 94	1445
			1547*	5414	99	15.6	33	16 @94, 1 @47	1491
			1594*	5578	102	15.6	34	17 @ 94	1536
			1641*	5742	105	15.6	35	17 @94, 1 @47	1581
			1688*	5906	108	15.6	36	18 @ 94	1627
S-480	360	235	1734	6070	111	15.6	37	17 @94, 3 @47	1671
			1781	6234	114	15.6	38	18 @94, 2 @47	1716
			1828	6398	117	15.6	39	19 @94, 1 @47	1761
			1875	6563	120	15.6	40	20 @ 94	1807
			1922*	6727	123	15.6	41	9 @ 141, 7 @94	1852
			1969*	6891	126	15.6	42	10 @141, 6 @94	1897
			2016*	7055	129	15.6	43	11 @141, 5 @94	1943
			2063*	7219	132	15.6	44	12 @141, 4 @94	1988
			2109*	7383	135	15.6	45	13 @141, 3 @94	2032
			2156*	7547	138	15.6	46	14 @141, 2 @94	2077
			2203*	7711	141	15.6	47	15 @141, 1 @94	2123
			2250*	7875	144	15.6	48	16 @ 141	2168

* High pressure only

Table 10. Model HSB Ratings 380V, 415V Supplies

Model	Vessel Capacity (gallons)	Steam Space (gallons)	Rated kW	ASME (Steam lbs/hr)	ELEMENTS		# of CONTACTORS	NUMBER and kW of STEPS	3-PHASE AMPERES	
					Qty	kW			380V/415V	380V
HSB-424	385	260	1650	5630	165	10	55	5@60, 15@90	2507	2296
			1680	5732	168	10	56	4@60, 16@90	2553	2337
			1710	5835	171	10	57	3@60, 17@90	2598	2379
			1740	5937	174	10	58	2@60, 18@90	2644	2421
			1770	6039	177	10	59	1@60, 19@90	2689	2463
			1800	6142	180	10	60	20@90	2735	2504

Table 11. Model HSB Ratings 480V Supply

MODEL #	Vessel Capacity (gallons)	Steam Space (gallons)	Rated kW	ASME (Steam lbs/hr)	ELEMENTS		# of CONTACTORS	NUMBER and kW of STEPS	3-PHASE AMPERES
					Qty	kW			
HSB-423	300	200	1560	5460	117	13.3	39	7 @120, 9 @80	1879
			1600	5600	120	13.3	40	8 @120, 8 @80	1927
			1640	5740	123	13.3	41	9 @120, 7 @80	1975
			1680	5880	126	13.3	42	10 @120, 6 @80	2025
			1720	6020	129	13.3	43	11 @120, 5 @80	2072
			1760	6160	132	13.3	44	12 @120, 4 @80	2120
			1800	6300	135	13.3	45	13 @120, 3 @80	2168
			1840	6440	138	13.3	46	14 @120, 2 @80	2216
			1880	6580	141	13.3	47	15 @120, 1 @80	2264
			1920	6720	144	13.3	48	16 @ 120	2313
HSB-424	385	260	1960	6860	147	13.3	49	1 @160, 15 @120	2361
			2000	7000	150	13.3	50	2 @160, 14 @120	2409
			2040	7140	153	13.3	51	3 @160, 13 @120	2457
			2080	7280	156	13.3	52	4 @160, 12 @120	2505
			2120	7420	159	13.3	53	5 @160, 11 @120	2553
			2160	7560	162	13.3	54	6 @160, 10 @120	2602
			2200	7700	165	13.3	55	7 @160, 9 @120	2650
			2240	7840	168	13.3	56	8 @160, 8 @120	2698
			2280	7980	171	13.3	57	9 @160, 7 @120	2746
			2320	8120	174	13.3	58	10 @160, 6 @120	2794
			2360	8260	177	13.3	59	11 @160, 5 @120	2843
			2400	8400	180	13.3	60	12 @160, 4 @120	2891

Table 11. Model HSB Ratings 480V Supply (Continued)

MODEL #	Vessel Capacity (gallons)	Steam Space (gallons)	Rated kW	ASME (Steam lbs/hr)	ELEMENTS		# of CONTACTORS	NUMBER and kW of STEPS	3-PHASE AMPERES
					Qty	kW			
HSB-425	470	320	2440	8540	183	13.3	61	13 @160, 3 @120	2939
			2480	8680	186	13.3	62	14 @160, 2 @120	2987
			2520	8820	189	13.3	63	15 @160, 1 @120	3035
			2560	8960	192	13.3	64	16 @ 160	3083
			2600	9100	195	13.3	65	11 @160, 7 @120	3132
			2640	9240	198	13.3	66	12 @160, 6 @120	3180
			2680	9380	201	13.3	67	13 @160, 5 @120	3228
			2720	9520	204	13.3	68	14 @160, 4 @120	3276
			2760	9660	207	13.3	69	15 @160, 3 @120	3324
			2800	9800	210	13.3	70	16 @160, 2 @120	3372
			2840	9940	213	13.3	71	17 @160, 1 @120	3421
			2880	10080	216	13.3	72	18 @ 160	3469

Table 12. Model HSB Ratings 600V Supply

MODEL #	Vessel Capacity (gallons)	Steam Space (gallons)	Rated kW	ASME (Steam lbs/hr)	ELEMENTS		# of CONTACTORS	NUMBER and kW of STEPS	3-PHASE AMPERES
					Qty	kW			
HSB-423	300	200	1734	6070	111	15.6	37	17 @94, 3 @47	1671
			1781	6234	114	15.6	38	18 @94, 2 @47	1716
			1828	6398	117	15.6	39	19 @94, 1 @47	1762
			1875	6563	120	15.6	40	20 @ 94	1807
			1922	6727	123	15.6	41	9 @141, 7 @94	1852
			1969	6891	126	15.6	42	10 @141, 6 @94	1897
			2016	7055	129	15.6	43	11 @141, 5 @94	1943
			2063	7219	132	15.6	44	12 @141, 4 @94	1988
			2109	7383	135	15.6	45	13 @141, 3 @94	2032
			2156	7547	138	15.6	46	14 @141, 2 @94	2078
			2203	7711	141	15.6	47	15 @141, 1 @94	2123
			2250	7875	144	15.6	48	16 @ 141	2168
HSB-424	385	260	2297	8039	147	15.6	49	13 @141, 5 @94	2213
			2344	8203	150	15.6	50	14 @141, 4 @94	2259
			2391	8367	153	15.6	51	15 @141, 3 @94	2304
			2438	8531	156	15.6	52	16 @141, 2 @94	2349
			2484	8695	159	15.6	53	17 @141, 1 @94	2394
			2531	8859	162	15.6	54	18 @ 141	2439
			2578	9023	165	15.6	55	15 @141, 5 @94	2484
			2625	9188	168	15.6	56	16 @141, 4 @94	2529
			2672	9352	171	15.6	57	17 @141, 3 @94	2575
			2719	9516	174	15.6	58	18 @141, 2 @94	2620
			2766	9680	177	15.6	59	19 @141, 1 @94	2665
			2813	9844	180	15.6	60	20 @ 141	2710

Table 12. Model HSB Ratings 600V Supply (Continued)

MODEL #	Vessel Capacity (gallons)	Steam Space (gallons)	Rated kW	ASME (Steam lbs/hr)	ELEMENTS		# of CONTACTORS 600V	NUMBER and kW of STEPS 600V	3-PHASE AMPERES 600V
					Qty	kW			
HSB-425	470	320	2859	10008	183	15.6	61	17 @141, 5 @94	2755
			2906	10172	186	15.6	62	18 @141, 4 @94	2800
			2953	10336	189	15.6	63	19 @141, 3 @94	2845
			3000	10500	192	15.6	64	20 @141, 2 @94	2891
			3047	10664	195	15.6	65	21 @141, 1 @94	2936
			3094	10828	198	15.6	66	22 @ 141	2981
			3141	10992	201	15.6	67	19 @141, 5 @94	3027
			3188	11156	204	15.6	68	20 @141, 4 @94	3072
			3234	11320	207	15.6	69	21 @141, 3 @94	3116
			3281	11484	210	15.6	70	22 @141, 2 @94	3161
			3328	11648	213	15.6	71	23 @141, 1 @94	3207
			3375	11813	216	15.6	72	24 @ 141	3252

PERFORMANCE DATA

Efficiency

Electric boilers are void of losses normally associated with fuel fired equipment such as stack loss, combustion loss, excess air loss, etc. Therefore electric boilers are nearly 100% efficient at all operating points. For hot water boilers, the only loss from 100% is the radiation loss from the vessel which is ½%. For steam units, in addition to the radiation loss, blowdown losses should be factored in.

Emissions

Since electric boilers are void of fuel combustion, no emissions occur. Therefore, electric boilers are well suited for installations that must meet stringent emissions requirements.

Noise Level

With not moving parts, the electric boiler is nearly noiseless and thus, is well suited for installations sensitive to noise emissions from mechanical equipment. Installations such as hospitals, nursing homes, schools, research laboratories, and the like are ideal for an electric boiler application.

Regardless of output from minimum to maximum, noise emissions are almost undetectable.

ENGINEERING DATA

Boiler Information - Hot Water

Cleaver-Brooks electric hot water boilers are designed for service in any closed hydronic system and can be used to augment any hot water system. They can be put into operation as a single stand-alone unit with high turndown or in multiple units for larger turndown and capacity.

C-B electric hot water boilers may be utilized in water heating systems with temperatures from 40⁰ F (4.4 C) to 245⁰ F (118.3 C); ideal for ground water source heat pump applications, etc. Because the WB is an electric boiler, low water temperature (below the dewpoint) restrictions do not apply.

Variable temperature differentials can be designed to make use of changing outdoor conditions and thus, the WB is not restrictive to a nominal 20⁰ F (10 C) differential. The boiler is designed to withstand thermal stresses with supply and return temperature differences of 100⁰ F (55 C) and greater. However, when the elements are on, water flow through the boiler must be ensured and a flow switch to prove water flow is recommended.

Flow Rates and Pressure Drops

To maintain rated capacity of the boiler, recommended flow rates should not be exceeded as the flow will remove the heat beyond the capacity of the boiler. **Table 13** can be used to determine the full boiler output relative to system temperature drop and the maximum recommended system pump flow.

The pressure drop through the boiler is < 1 psig.

Table 13. Model WB Max Flow Ratings Sheet 1 of 2

Model #	Rated kW	System Temperature Drop °F							
		10	20	30	40	50	60	70	80
		Maximum Flow Rate in GPM							
WB-120	12	8.2	4.5	3	2	1.75	1.5	1.25	1
	18	12.4	6.5	4.5	3.2	2.6	2	1.75	1.6
	24	16.5	8	5.5	4.1	3.2	2.75	2.3	2.1
	30	20.5	10.3	6.75	5.1	4.1	3.4	3	2.6
	36	24.5	12.25	8.2	6.2	4.9	4.1	3.5	3.1
	45	30.9	15.7	10.3	7.7	6.3	5.1	4.4	3.9
	54	37	18.4	12.3	9.2	7.4	6.1	5.3	4.6
	60	41	20.5	13.5	10.3	8.2	6.8	5.8	5.1
WB-121	72	49.5	24.2	16.5	12.3	9.8	8.2	7	6.1
	90	61.5	30.5	20.5	15.4	12.3	10.3	8.8	7.7
	108	73.6	37	24.7	18.5	14.8	12.3	10.6	9.2
	126	86	43	28.7	21.6	17.3	14.4	12.3	10.8
WB-122	144	98	49.2	32.9	24.6	19.7	16.5	14.1	12.3
	162	110.5	55.5	37	27.7	22.2	18.5	15.9	13.7
	180	122.6	61.5	41	30.8	24.6	20.5	17.6	15.4
	198	135.5	67.5	45	33.9	27.1	22.6	19.4	16.9
	216	148	74	49.3	37	29.6	24.6	21.1	18.5
	234	160	80	53.4	40	32	26.7	22.9	20
	252	172	86	57.5	43.1	34.5	28.8	24.6	21.6
	270	184.3	92.4	61.6	46.2	37	30.8	26.4	23.2
WB-201	288	196	98.5	65.7	49.3	39.5	32.9	28.2	24.6
	324	222	111	74	55.5	44.4	37	31.7	27.7
	360	246.5	123	82.2	61.6	49.3	41.1	35.2	30.8
	396	271	135.5	90.4	67.8	54.2	45.2	38.7	33.9
WB-202	432	296	148	98.6	74	59.2	49.3	42.3	37
	468	320	160.3	106.8	80.1	64.1	53.4	45.8	40
	504	345	172.5	115	86.3	69	57.5	49.3	43.2
	540	370	185	123.3	92.5	74	61.6	52.8	46.2
WB-241	576	394	197	131.5	98.6	79	65.7	56.4	49.3
	600	411	205.5	137	102.7	82.2	68.5	58.7	51.4
	630	431	215.5	143.8	107.9	86.3	71.9	61.6	53.9
	660	452	226	150.7	113	90.4	75.3	64.6	56.5
	690	472	236	157.5	118.2	94.5	78.8	67.5	59.1
WB-242	720	493	246.4	164.4	123.3	98.6	82.2	70.5	61.6
	750	514	257	171.2	128.4	102.7	85.6	73.4	64.2
	780	534	267	178.1	133.6	106.8	89	76.3	66.8
	810	555	277.5	185	138.7	110.9	92.5	79.2	69.3
	840	575	287.5	191.8	143.8	115.1	95.9	82.2	71.9
	870	596	298	198.6	150	119.2	99.3	85.1	74.5
	900	615	308	205.5	154.1	123.3	102.7	88.1	77
	930	637	318.5	212.3	159.2	127.4	106.2	91	79.6
	960	657	328.5	219.2	164.4	131.5	109.6	93.9	82.2

Table 13. Model WB Max Flow Ratings Sheet 2 of 2

Model #	Rated kW	System Temperature Drop °F							
		10	20	30	40	50	60	70	80
		Maximum Flow Rate in GPM							
WB-243	990	678	339	226	169.5	135.6	113	96.9	84.8
	1020	698	349	232.9	174.6	139.7	116.4	99.8	87.3
	1050	719	359.5	239.7	179.8	143.8	119.9	102.7	89.9
	1080	740	370	246.6	184.9	150	123.3	105.7	92.5
	1110	760	380	253.4	190	152.1	126.7	108.6	95
	1140	781	390.5	260.3	195.2	156.2	130.1	111.5	97.6
	1170	801	400.5	267.1	200.3	160.3	133.6	114.5	100.2
1200	822	411	274	205.5	164.4	137	117.4	102.7	
WB-361	1224	838	419	279.5	209.6	167.7	139.7	119.8	104.8
	1260	863	431.5	287.7	215.7	172.6	143.8	123.3	107.9
	1296	888	444	296	221.9	177.5	147.9	126.8	110.9
WB-362	1332	912	456	304.1	228.1	182.5	150.9	130.3	114
	1368	937	468.5	312.3	234.2	187.4	156.2	133.8	117.1
	1404	962	481	320.5	240.4	192.3	160.3	137.4	120.2
	1440	986	493	328.8	246.6	197.3	164.4	140.9	123.3
	1476	1011	505.5	337	252.7	202.2	168.5	144.4	126.4
	1512	1035	517.5	322.4	258.9	207.1	172.6	147.9	129.5
	1548	1060	530	353.4	265.1	212.1	176.7	151.5	132.5
	1584	1085	542.5	361.6	271.2	217	180.8	155	135.6
	1620	1109	554.5	370	277.4	221.9	184.9	158.5	138.7
	1656	1134	567	378	283.6	226.8	189	162	141.8
1692	1159	579.5	386.3	289.7	231.8	193.1	165.5	144.9	
1728	1183	591.5	394.5	295.9	236.7	197.3	169.1	147.9	
WB-363	1764	1208	604	402.7	302.2	241.6	201.4	172.6	151
	1800	1233	616.5	411	308.2	246.6	205.5	176.1	154.1
	1836	1257	628.5	419.2	314.4	251.5	209.6	179.6	157.2
	1872	1282	641	427.4	320.5	256.4	213.7	183.2	160.3
	1908	1307	653.5	435.6	326.7	261.4	217.8	186.7	163.4
	1944	1332	665.5	443.8	332.9	266.3	221.9	190.2	166.4
	1980	1356	678	452	339	271.2	226	193.7	169.5
	2016	1381	690.5	460.3	345.2	276.2	230.1	197.3	172.6
	2052	1405	702.5	468.5	350.6	281.1	234.2	200.8	175.7
	2088	1430	715	476.7	357.5	286	238.4	204.3	178.8
2160	1480	740	493.2	369.9	295.9	246.6	211.3	184.9	
WB-421	2240	1534	767	511.4	383.6	306.8	255.7	219.2	191.8
	2320	1589	794.5	529.7	397.3	317.8	264.8	227	198.6
	2400	1644	822	548	411	328.8	274	234.8	205.5
	2480	1699	849.5	566.2	424.6	339.7	283.1	242.7	212.3
	2560	1754	877	584.5	438.3	350.7	292.2	250.5	219.2
	2640	1808	904	602.7	452.1	361.6	301.4	258.3	226
WB-422	2720	1863	931.5	621	465.7	372.6	310.5	266.1	232.9
	2800	1918	959	639.3	479.5	383.6	319.6	274	239.7
	2880	1973	982.7	657.5	493.1	394.5	328.8	281.8	246.6
	3000	2055	1027.5	685	513.7	411	342.5	293.5	256.8
	3040	2082	1041	694	520.5	416.4	347	297.5	260.3
	3120	2137	1068.5	712.3	534.2	427.4	356.2	305.2	267.1
	3200	2192	1096	730.5	547.9	438.4	365.3	313.1	274
	3280	2247	1123	748.8	561.6	449.3	374.4	320.9	280.8
3360	2302	1151	767.1	575.3	460.3	383.6	328.8	287.7	

System Operating Parameters

To prevent water flashing to steam within the boiler or system, hot water boilers must operate with proper over pressure. System over pressure requirements are shown in **Table 14**.

While proper overpressure is required, a means to relieve excess pressure at or beyond the design pressure of the boiler must be provided. As boiler water is heated, expansion occurs. And this expansion must be accounted for either with an expansion tank (air filled) or with a bladder type tank. These devices permit the water pressure to expand outside of the boiler and not impact the pressure vessel or pressure relieving device. But, in accordance with Code, each boiler is equipped with an ASME approved safety relieving device should pressure build-up occur.

Table 14. Model WB Minimum Over Pressure Requirements

Outlet Water Temperature ⁰ F (C)	Minimum System Pressure PSIG (Bar)
80 - 180 (27 - 82)	12 (0.83)
181 - 185 (83 - 85)	15 (1.03)
186 - 195 (86 - 91)	18 (1.24)

Rule of Thumb Calculations

The following formula can be used to size a hot water boiler:

$$kW = \text{gph (gallons per hour)} \times \text{delta T (as expressed in } ^{\circ}\text{F)} \text{ divided by } 410$$

or

$$kW = 1 \text{ lph (liter per hour)} \times \text{delta T (as expressed in } ^{\circ}\text{C)} \text{ divided by } 862.$$

Where:

- kW is the boiler output rating.
- lph (liters per hour) or gph (gallons per hour) is the hot water flow rate.
- "delta T" is the temperature rise of water.

As an example:

$$kW = \text{gph} \times \text{delta T} / 410$$

$$kW = 5000 \times 20 / 410$$

$$kW = 100000 / 410$$

$$kW = 244$$

Boiler Information - Steam

Models CR, S, and HSB are designed for steam service and are built in accordance with the ASME Code for either low pressure (less than 15 psig operation) or high pressure (above 15 psig) steam applications .

For approximate conversion of pounds of steam to kW, the following can be used:

10 kW = 34 lbs. steam/hr = 1.02 boiler horsepower from and at 212 F.

It is important to know operating pressure and feedwater makeup temperature to properly size the steam boiler. From **Table 15**, one can obtain the pound of steam value for the operating pressure and corresponding feedwater makeup temperature. Based on this, the required kW size of the electric boiler can be determined.

For example: Steam load required of 2000 pounds per hour at an operating pressure of 100 psig and feedwater temperature of 170 degrees F. Referring to **Table 15**, we find the value of 0.3077 kW per pound of steam. We multiply the required pounds of steam by this value (2000 x 0.3077) and obtain 615. The required boiler would be 615 kW or the Model S-301-620, 150# design.

Table 15. kW per Pound of Steam

Feedwater Temperature (°F)	Boiler Operating Pressure (PSIG)				
	0	15	50	100	150
50	0.3318	0.3359	0.3401	0.3429	0.3441
70	0.3259	0.3300	0.3343	0.3370	0.3382
100	0.3171	0.3212	0.3255	0.3283	0.3294
120	0.3112	0.3154	0.3196	0.3224	0.3236
150	0.3025	0.3066	0.3108	0.3136	0.3148
170	0.2966	0.3001	0.3050	0.3077	0.3089
200	0.2878	0.2919	0.2962	0.2978	0.3001
212	0.2857	0.2898	0.2941	0.2957	0.2980
227	0.2836	0.2877	0.2920	0.2936	0.2967

Recommended Steam Nozzle Sizes

Recommended steam nozzle size to maintain 5000 ft/min steam velocity.

Table 16. Recommended Steam Nozzle Sizes

OPERATING PRESSURE (PSIG)	ELECTRIC BOILER kW												
	50	100	150	200	250	300	350	400	450	500	600	700	800
10	1.5	2	2.5	3	3	4	4	4	4	6	6	6	6
25	1.5	1.5	2	2.5	2.5	3	3	3	4	4	4	4	6
50	1.5	1.5	1.5	2	2	2.5	2.5	2.5	3	3	3	4	4
75	1.5	1.5	1.5	1.5	2	2	2	2.5	2.5	2.5	2.5	3	3
100	1.5	1.5	1.5	1.5	1.5	2	2	2	2	2.5	2.5	2.5	3
125	1.5	1.5	1.5	1.5	1.5	1.5	2	2	2	2	2.5	2.5	2.5
150	1.5	1.5	1.5	1.5	1.5	1.5	1.5	2	2	2	2	2.5	2.5
175	1.5	1.5	1.5	1.5	1.5	1.5	1.5	1.5	2	2	2	2	2.5
200	1.5	1.5	1.5	1.5	1.5	1.5	1.5	1.5	1.5	1.5	2	2	2
225	1.5	1.5	1.5	1.5	1.5	1.5	1.5	1.5	1.5	1.5	2	2	2

OPERATING PRESSURE (PSIG)	ELECTRIC BOILER kW												
	900	1000	1200	1400	1600	1800	2000	2200	2400	2600	2800	3000	3200
10	6	6	8	8	8	8	10	10	10	10	10	12	12
25	6	6	6	6	6	8	8	8	8	8	8	10	10
50	4	4	6	6	6	6	6	6	6	8	8	8	8
75	4	4	4	4	6	6	6	6	6	6	6	6	6
100	3	3	4	4	4	4	6	6	6	6	6	6	6
125	2.5	3	3	4	4	4	4	4	6	6	6	6	6
150	2.5	2.5	3	3	4	4	4	4	4	4	6	6	6
175	2.5	2.5	2.5	3	3	4	4	4	4	4	4	4	6
200	2.5	2.5	2.5	3	3	3	4	4	4	4	4	4	4
225	2	2.5	2.5	2.5	3	3	3	3	4	4	4	4	4

Water Treatment

Even though hot water systems are “closed”, some amount of make-up water (up to 10%) will be introduced, usually due to pump seal leaks or other minimal leaks from valves etc., that go unnoticed. Therefore, proper water chemistry of a hot water boiler is necessary for good operation and longevity, particularly to ensure that free oxygen is removed to prevent waterside corrosion.

Table 17. Water Quality

Parameter	Hot Water Boiler Limit	Steam Boiler Limit
pH	8.3 - 9.5	8.3 - 10.5
Iron	0.1 ppm	0.1 ppm
Alkalinity	<300 ppm	<600 ppm
Chlorides	30 mg/liter	30 mg/liter
Oxygen	0.1 mg/liter	0.1 mg/liter
Specific Conductivity	3500 μ mho/cm	4500 μ mho/cm
Total Hardness	<3 ppm	<3 ppm

For steam boilers, proper blowdown (surface and bottom) is a required maintenance procedure. This water loss and associated steam use or loss must be made up. Any make-up water should be properly treated prior to introduction into the boiler via water softener, chemical feed, etc. Proper water chemistry in a steam boiler is mandatory for effective operation and longevity.

See **Table 17** for water quality requirements.

Boiler Room Information

The boiler must be installed on a level non-combustible surface. If the surface is not level, piers or a raised pad (slightly larger than the length and width of the boiler base dimensions) will make boiler leveling possible. Installing the boiler on a raised pad or piers will make boiler drain connections more accessible and will keep water from splashing onto the boiler when the boiler room floor is washed. NOTE: The pad or piers must be of sufficient load bearing strength to safely support the operating weight of the boiler and any additional equipment installed with it. Approximate operating weights are shown in Dimensions and Ratings.

Clearances

The boiler must be installed so that all components remain accessible, especially be free of side mounted piping so the element flanges may be opened. Refer to Dimension Sheets **Figure 1** through **Figure 4**.

Hot Water Piping

Primary/Secondary Pumps are not necessary with the electric hot water boilers, although they can be used. As its design is such that thermal shock is not a concern, some flow is required whenever the boiler elements are on. Therefore, whether primary/secondary or system pump, an interlock such as a flow switch should be employed to ensure that water flow is established before the boiler elements are allowed on.

Electrical

Voltage requirements for the electric boilers are as noted in the ratings sheets including the relative ampacity.

Switchgear above 600 amps will not be furnished by Cleaver-Brooks due to the overall size of the equipment and NEC Code requirement for switchgear wiring. The larger switchgear wiring requirements exceed the UL certification of the package boiler.

Power Connection Lug Sizing

Table 18. Power Distribution Blocks

AMPS	CONNECTOR MATERIAL	LINE SIDE	
		WIRE RANGE (AWG/kcmil)	CONNECTOR OPENINGS/ POLE
175	AL	2/0 - #14	1
335	AL	400 - #6	1
380	AL	500 - #4	1
760	AL	500 - #4	2
1520	AL	500 - #4	4
1900	AL	750 - 3/0	(3)4
2850	AL	750 - 3/0	(3)6
3800	AL	750 - 3/0	(3)8

Table 19. Disconnect Terminal Lugs

DISCONNECT TYPE	AMPS	CONNECTOR MATERIAL	LINE SIDE	
			WIRE RANGE (AWG/kcmil)	CONNECTOR OPENINGS/ POLE
Non-Fusible	30	CU	2/0 - #12	1
Fusible	30	CU	#10 - #14	1
Non-Fusible	60	CU	2/0 - #12	1
Fusible	60	CU	#6 - #10	1
Non-Fusible	100	AL	2/0 - #12	1
Fusible	100	CU	#1 - #12	1
Non-Fusible, Fusible	200	AL	300 - #6	1
Non-Fusible, Fusible	200	CU	300 - #6	1
Non-Fusible, Fusible	400	AL	600 - #4, 250 - 1/0	1, 2
Non-Fusible, Fusible	400	CU	600 - #4, 250 - 1/0	1, 2
Non-Fusible, Fusible	600	AL	600 - #2	2
Non-Fusible, Fusible	800	AL	600 - #2	x 3
Non-Fusible, Fusible	1200	AL	600 - #2	x 4
Non-Fusible, Fusible	1600	AL	600 - #4	x 5
Non-Fusible, Fusible	2000	AL	600 - #4	x 6
Non-Fusible, Fusible	2500	AL	600 - #4	x 7
Non-Fusible, Fusible	3000	AL	600 - #4	x 8
Non-Fusible, Fusible	4000	AL	600 - #4	x 12

Table 20. Grounding Lugs

MOCP	LINE SIDE	
	WIRE RANGE (AWG/kcmil)	CONNECTOR OPENINGS/ POLE
300	#4 - #14	1
1000	2/0 - #14	1
2000	250 - #6	1
4000	500 - #4	1
6000	800 - 300	1



e-mail: info@cleaverbrooks.com
Web Address: <http://www.cleaverbrooks.com>