



# Electric Steam and Hot Water Boilers

A complete line of packaged boilers  
From 12 to 1000 kW (1.2 to 100 BHP)



# FULTON ELECTRIC STEAM AND HOT WATER BOILERS

## FEATURES

- Nearly 100% efficient
- Quiet, clean
- No emissions
- Small footprint - compact design
- Built/Certified to ASME, CSD-1, UL Packaged Boiler
- Ideal choice where fossil fuels are not available or where electricity rates are favorable
- Completely wired control panel box located in front of the boiler
- Safe, solid state relays, all wiring meets NEC specifications

## EFFICIENT, QUIET, SAFE OPERATION

Fulton manufactures a complete line of electric steam and hot water boilers from 12 kW to 1,000 kW (1.2 to 100 BHP) up to 300 PSI for heating and process applications. Custom units are also available up to 800 PSI.

Fulton's vertical design is a fully packaged steam boiler built to ASME specifications and applicable standards and codes. They are very efficient because the heating elements are totally immersed in water and the pressure vessel is fully insulated. Radiation losses are minimal. With a carefully calculated heat-to-steam ratio, operating pressures are achieved quickly with maximum efficiency. Electric boilers have no wasted fuel going out the stack as associated with fossil fuels; therefore, electric boilers are environmentally friendly. No NOx (nitrogen oxides) are being transmitted to the atmosphere.



*Shown here are two all stainless steel skid mounted steam boiler systems. The boilers supply clean steam to a bio-reactor for a fermentation plant.*

# RUGGED, ROBUST AND RELIABLE

## STAINLESS STEEL HEATING ELEMENTS

Fulton uses low watt density elements made of stainless steel. Stainless will not melt or anneal as easily as copper elements which ensures a long life expectancy. The small 12 to 36 kW boilers use horizontally mounted elements near the bottom of the boiler while the 50 to 1,000 kW elements mount vertically. Fulton also offers optional Incoloy elements which remain stable during extended exposure to high temperatures and offer an increased resistance to stress corrosion.

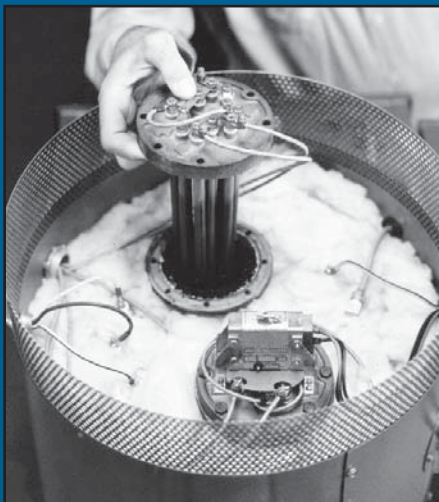
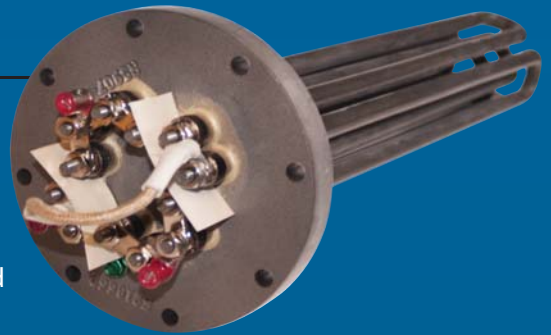

## ROBUST MANUFACTURING

Intelligent designs maximize boiler pressure vessel integrity and increase life expectancy. Our construction parameters typically include material thicknesses 30% greater than ASME minimum requirements. Stainless units are available for RO/DI water or Clean Steam applications.

## EASILY INSPECTED AND MAINTAINED

The elements in each of the models are easily accessible and permit quick removal for service or inspection by simply unbolting the element(s) from the flanges in the top or side of the boiler. Expansion and contraction of the elements cause scale to flake off and drop to the bottom of the boiler. Strategically located 3" x 4" handholes allow easy inspection and periodic clean-out maintenance.

## CRAFTSMANSHIP

All Fulton boilers are hand-built by skilled craftsmen. The impressive workmanship that goes into constructing the pressure vessels is performed by Fulton's ASME certified welders, who average over 20 years of experience.



**STRONGER MATERIALS + SMARTER ENGINEERING + SUPERIOR CRAFTSMANSHIP = FULTON**

# COMPONENTS

## COMPONENT LOCATIONS

## 50 to 200 kW (5 to 20 BHP)

1. Pressure Vessel Is Built To ASME Code
2. Electrical Control Panel Box
3. Electric Heating Elements
4. Low Water Cut Off Probe
5. Auxiliary Low Water Cut Off Probe
6. Pump "On" Probe
7. Pump "Off" Probe
8. Sight Glass Assembly
9. Operating Pressure Control
10. High Limit Pressure Control
11. Steam Outlet
12. Safety Valve
13. Steam Gauge Assembly
14. Steam Pressure Gauge
15. High Temp Insulation Surrounds The Vessel
16. Large (3" x 4") Easily Access Handholes
17. Feedwater Shut-Off Valve
18. Blowdown Valve
19. Water Bottle Assembly (300 to 1000 kW models only)

Elements are vertically mounted. All probes are mounted in the top of the boiler.

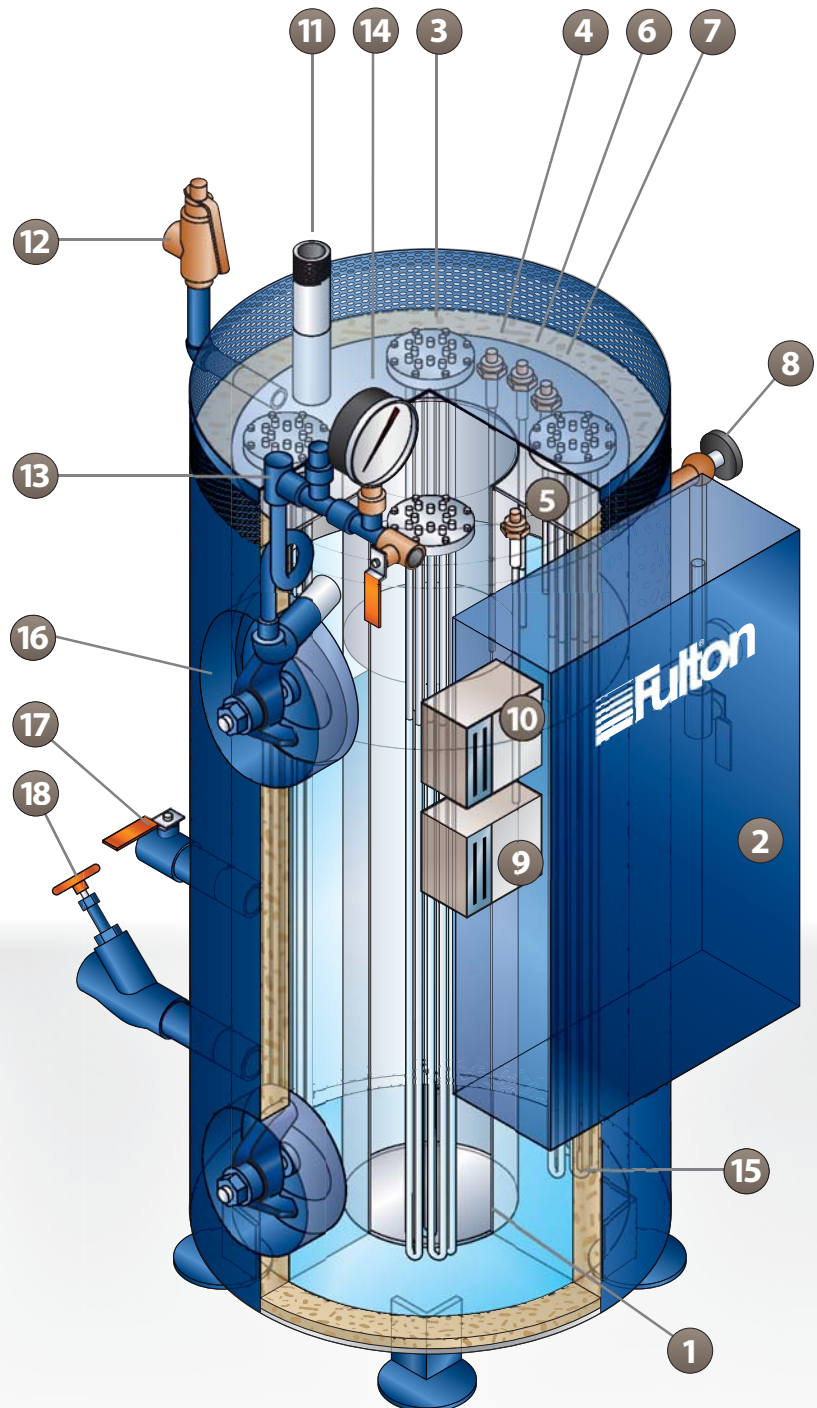

## 12 to 36 kW (1.2 to 3.6 BHP)

Element(s) are horizontally mounted at the bottom of the pressure vessel. All probes are located in the top of the boiler.

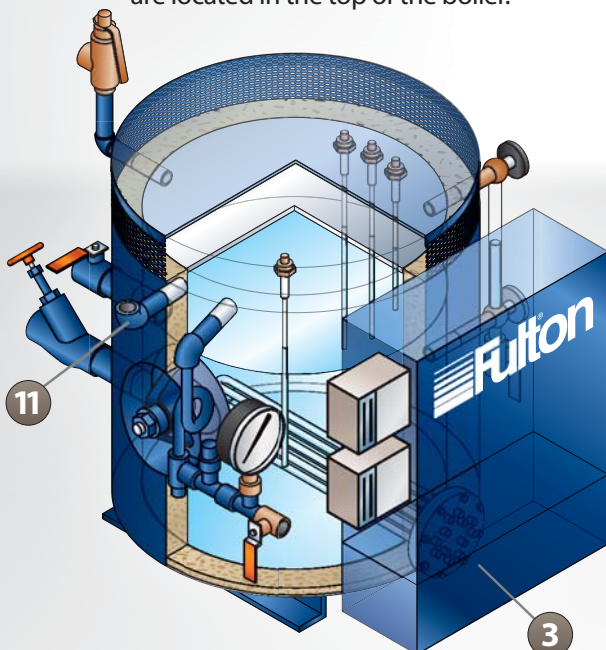

# A LOOK INSIDE

300 to 1000 kW (30 to 100 BHP)

Elements are vertically mounted. These boilers have an externally mounted water bottle assembly housing the low water cut-off probe, pump on probe and pump off probe. The second (auxiliary) low water cut off probe is mounted in the top of the boiler.

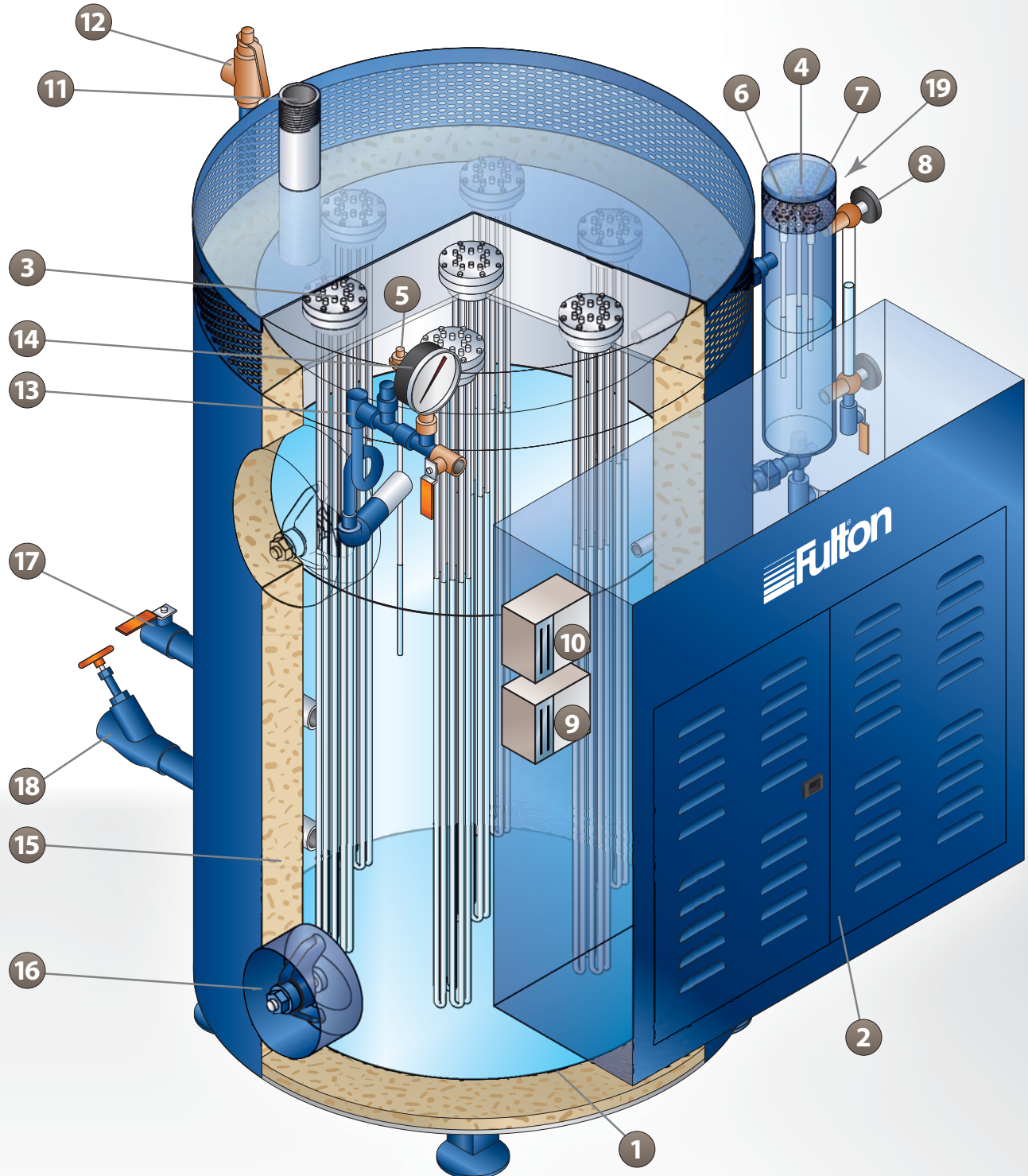

# ENGINEERED SYSTEMS

## DESIGNED AND BUILT IN ONE PLACE

As demand for creative solutions to complex heat transfer applications grows, Fulton has excelled in the design and fabrication of customized skid systems. With more than three decades of experience in designing and building skid systems, Fulton has become the leading manufacturer for custom pre-piped heat transfer equipment and accessories.

Our team of engineers, technicians, and project managers can help you choose all the best equipment for your specific application. Then our highly experienced craftsmen act as your single source fabricators to build a rugged system that will withstand the daily rigors of any application imaginable. All engineered systems come with state-of-the-art operating controls and can have single point connections ready for power and water hook up at the site. This saves you a tremendous amount of time, money and aggravation. It's all designed and built specifically for you. Fulton builds the most Rugged, Robust, and Reliable heat transfer systems in the business.

- Highly experienced staff
- Collaborative approach
- Single source responsibility
- Simplification of installation
- Turnkey operation
- Skids moved economically

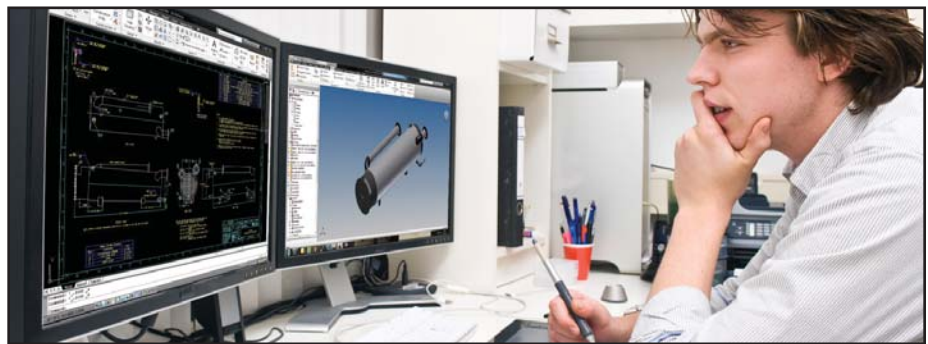

*The system pictured here contains an electric steam boiler with a blowdown tank, a return / feedwater tank, water softener, chemical feed system, system pump, and a superheater. This unit supplies clean steam for an autoclave in a hospital setting.*



# FROM START TO FINISH

## ALL STAINLESS STEEL SYSTEMS

Fulton is able to produce complete stainless systems for use in domestic hot water and clean steam applications that require extra resistance to corrosion. The system pictured here contains a 50 kW stainless electric steam boiler with all stainless piping, a stainless return / feedwater tank, a blowdown tank, and a stainless system pump. This unit supplies clean steam for the manufacturing of pacemakers.

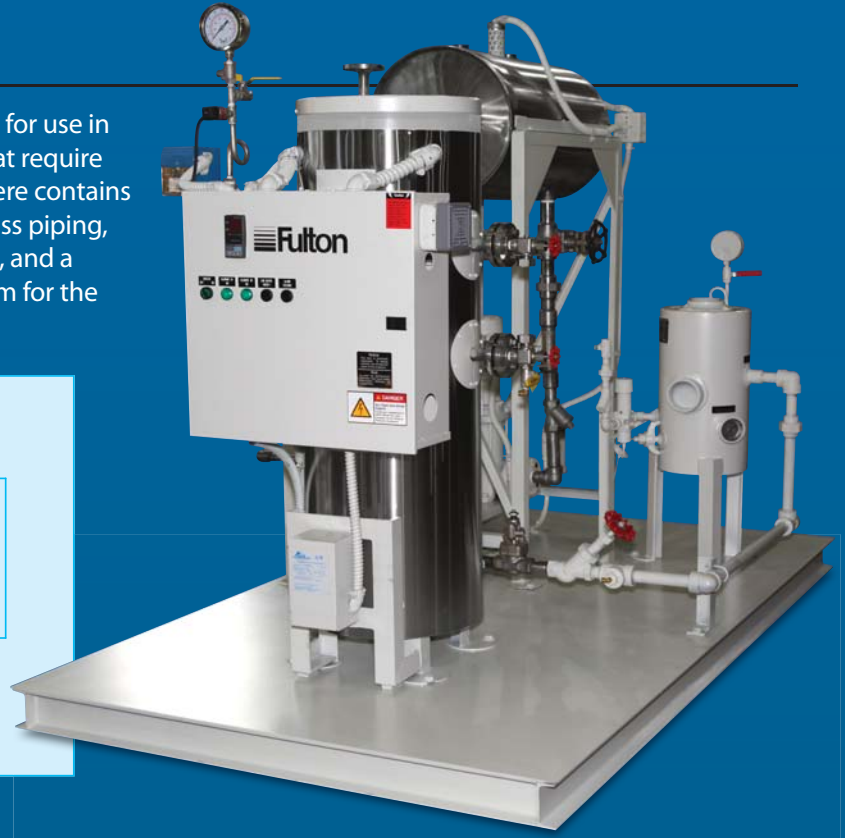
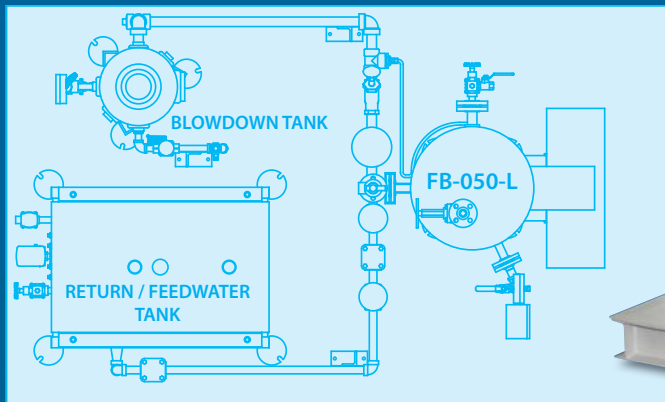

## ANCILLARY EQUIPMENT

A steam boiler is just one part of a well-designed steam system. Proper delivery of feedwater and collection of condensate are essential to the operation of a steam system. Fulton is able to manufacture standard or custom vessels to perform these tasks to ASME code or non-code, depending on the requirements in your area or system. Our auxiliary equipment is used to control the quality, pressure, storage capacity and enthalpy (heat content or temperature) of steam. The quality of the water used in a steam boiler will affect its life. Water treatment equipment will help provide quality feedwater so that corrosion and deposition in the boiler will be minimized.

Fulton engineers can match equipment to just about any application you may encounter today.



# SPECIFICATIONS AND DIMENSIONS

Model FB-L (Steam Boiler)		012	015	018	024	030	036	050	075	100	150	200	300	500	750	1,000	
Unit Size	kW	12	15	18	24	30	36	50	75	100	150	200	300	500	750	1,000	
	HP	1.2	1.5	1.8	2.4	3.0	3.6	5.0	7.5	10	15	20	30	50	75	100	
<b>DIMENSIONS</b>																	
Number Of Elements		1	1	1	2	2	2	2	3	4	6	4	4	7	10	14	
(A) Boiler Height	IN	24	24	24	24	24	24	55	55	55	55	55	75.5	75.5	75.5	75.5	
	MM	610	610	610	610	610	610	1397	1397	1397	1397	1397	1918	1918	1918	1918	
(B) Boiler Height with Piping	IN	34.5	34.5	34.5	34.5	34.5	34.5	61	61	61	61	61	81	81	81	81	
	MM	876	876	876	876	876	876	1549	1549	1549	1549	1549	2057	2057	2057	2057	
(C) Boiler Diameter	IN	20	20	20	20	20	20	17	24	24	28	32	36	44	50	63	
	MM	508	508	508	508	508	508	432	610	610	711	813	914	1118	1270	1600	
(D) Overall Depth	IN	33	33	33	33	33	33	27.5	36	42	42	48.5	54.5	61	72	85.5	
	MM	838	838	838	838	838	838	699	914	1067	1067	1232	1384	1549	1829	2172	
(E) Boiler Width Overall	IN	33	33	33	33	33	33	35.5	35.5	41	44	48	57	64	69	82	
	MM	838	838	838	838	838	838	902	902	1041	1118	1219	1448	1626	1753	2083	
Steam Output**	LB/HR	40	50	61	81	101	122	170	255	341	511	683	1024	1707	2561	3415	
	KG/HR	18	23	28	37	46	55	77	116	155	232	310	464	774	1162	1549	
<b>ELECTRICAL POWER</b>																	
208V / 3 Phase	Amps	34	42	50	67	84	100	139	209	278	417	556	833	*	*	*	
230V / 3Phase	Amps	31	38	46	61	76	91	126	189	252	377	503	754	*	*	*	
460V / 3Phase	Amps	16	19	23	31	38	46	63	95	126	189	252	377	628	942	1256	
575V / 3Phase	Amps	13	16	19	25	31	37	51	76	101	151	201	302	503	754	1005	

## FB-L Steam Models

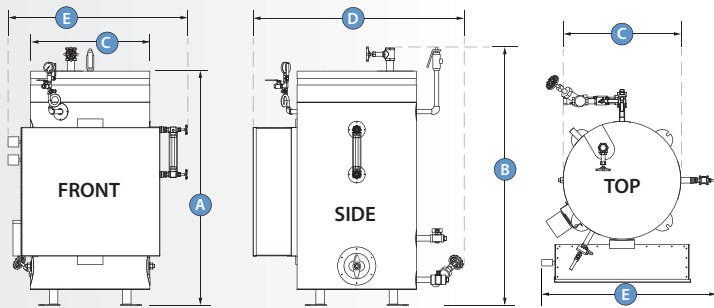

## FB-W Hot Water Models

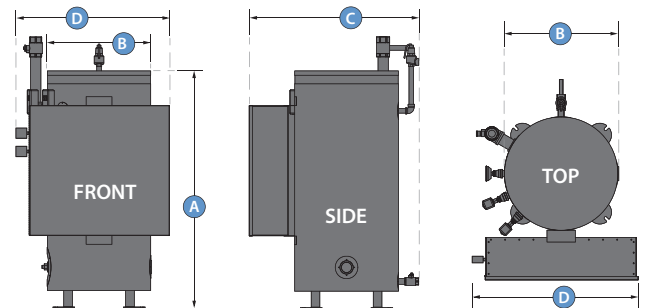

Model FB-W (Hot Water Boiler)		012	015	018	024	030	036	050	070	105	140	175	210	280	350	420	490	560	630	700	
Unit Size	kW	12	15	18	24	30	36	50	70	105	140	175	210	280	350	420	490	560	630	700	
	HP	1.2	1.5	1.8	2.4	3	3.6	5	7	10.5	14	17.5	21	28	35	42	49	56	63	70	
<b>DIMENSIONS</b>																					
Number Of Elements		1	1	1	2	2	2	2	2	3	4	5	6	4	5	6	7	8	9	10	
(A) Boiler Height	IN	24	24	24	24	24	24	55	55	55	55	55	55	55	55	55	55	55	55	55	
	MM	610	610	610	610	610	610	1397	1397	1397	1397	1397	1397	1397	1397	1397	1397	1397	1397	1397	
(B) Boiler Diameter	IN	20	20	20	20	20	20	17	24	24	28	28	36	40	40	44	44	44	50	50	
	MM	508	508	508	508	508	508	432	610	610	711	711	914	1016	1016	1118	1118	1118	1270	1270	
(C) Overall Depth	IN	34	34	34	34	34	34	31	31	38	39	43	43	54	59	59	60	67	67	70	
	MM	864	864	864	864	864	864	787	787	965	991	1092	1092	1372	1499	1499	1524	1702	1702	1778	
(D) Boiler Width Overall	IN	30	30	30	30	30	30	23	23	32	32	37	40	41	53	53	53	58	64	64	
	MM	762	762	762	762	762	762	584	584	813	813	940	1016	1041	1346	1346	1346	1473	1626	1626	
Output	1,000 BTU/HR	41	51	62	82	103	124	172	241	362	483	603	724	966	1207	1449	1690	1932	2173	2415	
	1,000 KCAL/HR	10	13	16	21	26	31	43	61	91	122	152	182	243	304	365	426	487	548	609	
<b>ELECTRICAL POWER</b>																					
208V / 3 Phase	Amps	34	42	50	67	84	100	139	195	292	389	486	583	778	*	*	*	*	*	*	
230V / 3Phase	Amps	31	38	46	61	76	91	126	176	264	352	440	528	703	879	1055	1231	*	*	*	
460V / 3Phase	Amps	16	19	23	31	38	46	63	88	132	176	220	264	352	440	528	616	703	791	879	
575V / 3Phase	Amps	13	16	19	25	31	37	51	71	106	141	176	211	282	352	422	493	563	633	703	

Specifications and Dimensions are approximate. We reserve the right to change specifications and/or dimensions without notice. Voltage applied higher than above ratings will result in higher amp draws.

### Notes:

\* Indicates voltages may be available at special request.

\*\* Steam output ratings, at 212°F feedwater. (0 PSIG)



### The Fulton Companies

972 Centerville Road, Pulaski, NY 13142  
Call: (315) 298-5121 • Fax: (315) 298-6390



www.fulton.com

electric-bro\_2012-0614