

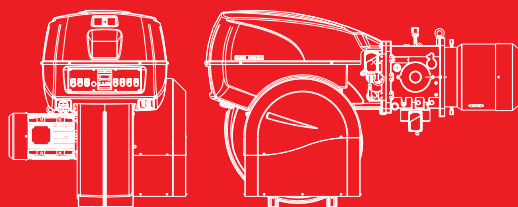

RS 300÷1200/E-EV BLU Series

Low NOx Modulating Gas Burners

RS 300/E-EV BLU	500/1350	÷ 3800 kW
RS 400/E-EV BLU	800/1840	÷ 4550 kW
RS 500/E-EV BLU	1000/2500	÷ 5170 kW
RS 650/E-EV BLU	1410/3020	÷ 6500 kW
RS 800/E-EV BLU	1200/3500	÷ 8100 kW
RS 1000/E-EV BLU	1100/4000	÷ 10100 kW
RS 1200/E-EV BLU	1500/5500	÷ 11100 kW



The RS/E and RS/EV series burners are characterised by a modular monoblock structure that means all necessary components can be combined in a single unit thus making installation easier, faster and, above all, more flexible.

The series covers a firing range from 1350 to 11100 kW, and they have been designed for use in hot water boilers or industrial steam generators.

Operation can be "two stage progressive" or alternatively "modulating" with the installation of a PID logic regulator on the RS/E series burners while RS/EV series is fully "modulating".

The mechanisms of regulation allow to catch up a high modulation ratio on all firing rates range.

The burner can, therefore, supply with precision the demanded power, guaranteeing an high efficiency system level and the stability setting, obtaining fuel consumption and operating costs reduction.

The burner operation can be intermittent or continuous by menu setting.

The innovative combustion head, adjustment system ensures perfect movement during modulation as well as reducing noise and pollutants.

Technical Data

MODEL			RS 300/E - EV BLU	RS 400/E - EV BLU	RS 500/E - EV BLU
Burner operation mode			Modulating		
Modulation ratio at max. output			5 ÷ 1		
Servomotor	type	SQM45 (gas) - SQM 48 (air)			
	run time s	--			
Heat output	kW	500/1350 ÷ 3800	800/1840 ÷ 4550	1000/2500 ÷ 5170	
	Mcal/h	430/1161 ÷ 3268	688/1582 ÷ 3912	860/2150 ÷ 4446	
Working temperature	°C min./max.	0/60			
FUEL/AIR DATA					
G20 gas	net calorific value	kWh/Nm ³	10		
	gas density	kg/Nm ³	0.71		
	gas delivery	Nm ³ /h	50/135 ÷ 380	80/180 ÷ 450	100/250 ÷ 516
G25 gas	net calorific value	kWh/Nm ³	8.6		
	gas density	kg/Nm ³	0.78		
	gas delivery	Nm ³ /h	58/156 ÷ 442	93/209 ÷ 523	116/290 ÷ 601
LPG gas	net calorific value	kWh/Nm ³	25.8		
	gas density	kg/Nm ³	2.02		
	gas delivery	Nm ³ /h	--		
Fan	type	Reverse curve blades			
Air temperature	max °C	60			
ELECTRICAL DATA					
Electrical supply	Ph/Hz/V	3N/50/230-400 (±10%)		3N/50/400 (±10%)	
Auxiliary electrical supply	Ph/Hz/V	1/50/230 ~ (±10%)			
Control box	type	LMV51.../LMV52...			
Total electrical power	kW	6	9.2	10.8	
Auxiliary electrical power	kW	--			
Protection level	IP	54			
Fan motor	electrical power	kW	4.5	7.5	9.2
	rated current	A	15 - 8.7	13.8 - 8	16.9 - 9.7
	start up current	A	7 x In		
	protection level	IP	54		
Ignition transformer	V1 - V2	230V - 2 x 5 kV			
	I1 - I2	1.9 A - 35 mA			
Operation	Intermittent (at least one stop every 24 h) or Progressive two-stage or modulating by kit				
EMISSIONS					
Noise levels	sound pressure	dB (A)	82	85	88
	sound power	W	-	-	-
Gas G20	CO emission	mg/kWh	< 10		
	NOx emission	mg/kWh	< 80		
APPROVAL					
Directive	2006/42 - 2009/142 - 2004/108 - 2006/95 EC				
Conforming to	EN 676 - EN 12100				
Certification	CE-0085B00341	CE-0085B00341	CE-0085B00341	CE-0085B00341	

Reference conditions:

Temperature: 20°C - Pressure: 1013,5 mbar - Altitude: 0 m a.s.l. - Noise measured at a distance of 1 meter.

Since the Company is constantly engaged in the production improvement, the aesthetic and dimensional features, the technical data, the equipment and the accessories can be changed. This document contains confidential and proprietary information of RIELLO S.p.A. Unless authorised, this information shall not be divulged, nor duplicated in whole or in part.

MODEL		RS 650/E - EV BLU	RS 800/E - EV BLU	
Burner operation mode		Modulating		
Modulation ratio at max. output		5 ÷ 1		
Servomotor	type	SQM45 (gas) - SQM 48 (air)		
	run time s	--		
Heat output	kW	1410/3030 ÷ 6500	1200/3500 ÷ 8100	
	Mcal/h	1212/2605 ÷ 5589	1032/3009 ÷ 6965	
Working temperature	°C min./max.	0/60		
FUEL/AIR DATA				
G20 gas	net calorific value	kWh/Nm ³	10	
	gas density	kg/Nm ³	0.71	
	gas delivery	Nm ³ /h	143/300 ÷ 655	175/350 ÷ 800
G25 gas	net calorific value	kWh/Nm ³	8.6	
	gas density	kg/Nm ³	0.78	
	gas delivery	Nm ³ /h	166/349 ÷ 762	139/407 ÷ 942
LPG gas	net calorific value	kWh/Nm ³	25.8	
	gas density	kg/Nm ³	2.02	
	gas delivery	Nm ³ /h	55.4/116.3 ÷ 253.9	--
Fan	type	Forward curve blades		
Air temperature	max °C	60		
ELECTRICAL DATA				
Electrical supply	Ph/Hz/V	3N/50/400 (±10%)		
Auxiliary electrical supply	Ph/Hz/V	1/50/230 ~ (±10%)		
Control box	type E/EV	LMV51.../LMV52...		
Total electrical power	kW	20.8	24.5	
Auxiliary electrical power	kW	--		
Protection level	IP	54		
Fan motor	electrical power	kW	18.5	22
	rated current	A	35.7 - 20.6	41.8 - 24.2
	start up current	A	8 x Nom	
	protection level	IP	54	
Ignition transformer	V1 - V2	230V - 1 x 5 kV		
	I1 - I2	1 A - 20 mA		
Operation		Continuos / Intermittent (at least one stop every 24 h)		
EMISSIONS				
Noise levels	sound pressure	dB (A)	90.1	88.1
	sound power	W	104.3	102.5
Gas G20	CO emission	mg/kWh	< 10	
	NOx emission	mg/kWh	< 80	
APPROVAL				
Directive		2006/42 - 2009/142 - 2004/108 - 2006/95 EC		
Conforming to		EN 676 - EN12100		
Certification		CE-0085BT0337	CE-0085BT0337	

Reference conditions:

Temperature: 20°C - Pressure: 1013,5 mbar - Altitude: 0 m a.s.l. - Noise measured at a distance of 1 meter.

Since the Company is constantly engaged in the production improvement, the aesthetic and dimensional features, the technical data, the equipment and the accessories can be changed. This document contains confidential and proprietary information of RIELLO S.p.A. Unless authorised, this information shall not be divulged, nor duplicated in whole or in part.

MODEL			RS 1000/E - EV BLU	RS 1200/E - EV BLU
Burner operation mode			Modulating	
Modulation ratio at max. output			5 ÷ 1	
Servomotor	type	SQM45 (gas) - SQM 48 (air)		
	run time s	--		
Heat output	kW	1100/4000 ÷ 10100	1500/5500 ÷ 11100	
	Mcal/h	946/3440 ÷ 8686	1290/4730 ÷ 9546	
Working temperature	°C min./max.	0/60		
Fuel/Air Data				
G20 gas	net calorific value	kWh/Nm ³	10	
	gas density	kg/Nm ³	0.71	
	gas delivery	Nm ³ /h	50/135 ÷ 380	80/180 ÷ 450
G25 gas	net calorific value	kWh/Nm ³	8.6	
	gas density	kg/Nm ³	0.78	
	gas delivery	Nm ³ /h	58/156 ÷ 442	93/209 ÷ 523
LPG gas	net calorific value	kWh/Nm ³	25.8	
	gas density	kg/Nm ³	2.02	
	gas delivery	Nm ³ /h	--	
Fan	type	Reverse curve blades		
Air temperature	max °C	60		
Electrical Data				
Electrical supply	Ph/Hz/V	3N/50/230-400 (±10%)		
Auxiliary electrical supply	Ph/Hz/V	1/50/230 ~ (±10%)		
Control box	type E/EV	LMV51.../LMV52...		
Total electrical power	kW	6	9	
Auxiliary electrical power	kW	--		
Protection level	IP	54		
Fan motor	electrical power	kW	21	25
	rated current	A	41.8 - 24.2	44.1 - 25.5
	start up current	A	7 x I _n	
	protection level	IP	54	
Ignition transformer	V1 - V2	230V - 2 x 5 kV		
	I1 - I2	1.9 A - 35 mA		
Operation		Intermittent (at least one stop every 24 h) or continuous (at least one stop every 72 h)		
Emissions				
Noise levels	sound pressure	dB (A)	85	89.3
	sound power	W	99	99.7
Gas G20	CO emission	mg/kWh	< 10	
	NOx emission	mg/kWh	< 80	
Approval				
Directive		2006/42 - 2009/142 - 2004/108 - 2006/95 EC		
Conforming to		EN 676 - EN12100		
Certification		CE-0085CN0119	CE-0085CN0120	

Reference conditions:

Temperature: 20°C - Pressure: 1013,5 mbar - Altitude: 0 m a.s.l. - Noise measured at a distance of 1 meter.

Since the Company is constantly engaged in the production improvement, the aesthetic and dimensional features, the technical data, the equipment and the accessories can be changed. This document contains confidential and proprietary information of RIELLO S.p.A. Unless authorised, this information shall not be divulged, nor duplicated in whole or in part.

Firing Rates

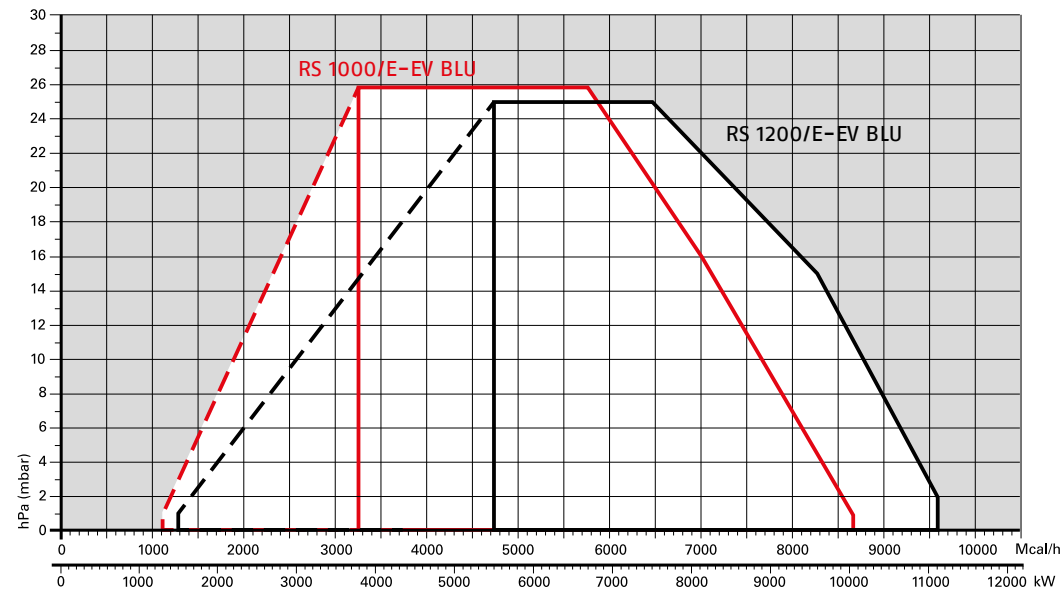
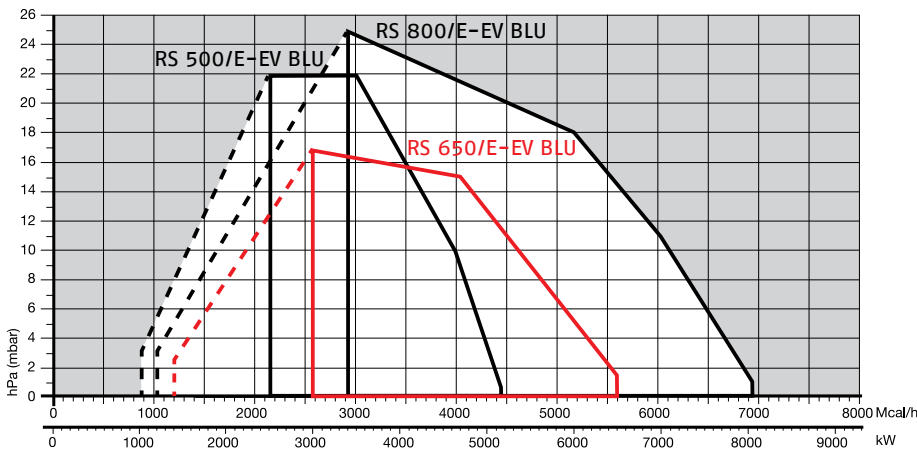
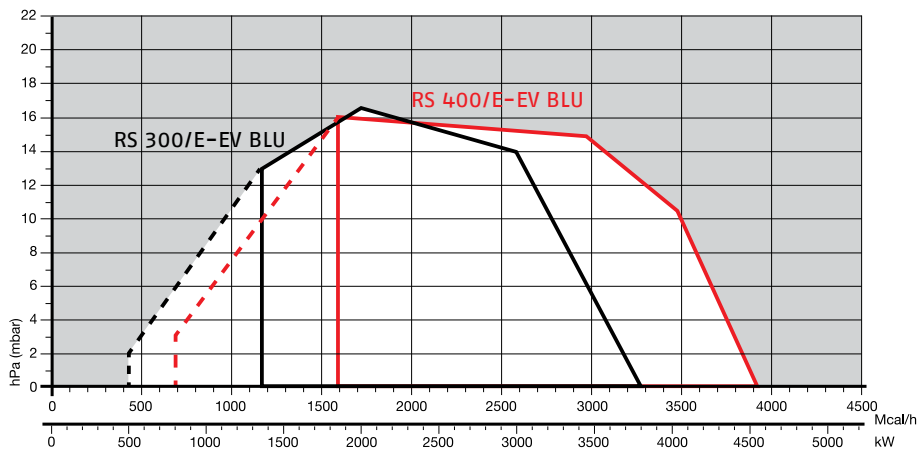

GAS TRAIN DESIGNATION

Series: MB

MBC
DMV
DMV12
VGD
CB
CBH
MV
CG

Size:	405	407	410	412	415	420							
		65	120	300	700	1200	-	1900	3100	5000			
	505	507	510	512	-	520	525	5065	5080	50100	50125	50150	
	10	15	20	32	40	-	50	-	65	80	100	125	150
		120	220										

Operation:

/S	only ON-OFF function
/1	stage mode opening
/2	2nd stage mode opening
/P	1st stage mode opening with air/gas proportional regulator

Leak detection control:

-	0
CT	leak detection control device installed on the gas train
CQ	equipped with pressure switch for leak detection control

Joint type:

R	threaded joint
F	standard flange ISO
F1	square flange BS1
F2	square flange BS2
F3	square flange BS3 - BS4

Electrical connection:

T	Terminals - Terminal strip
SD	Domestic plug
SM	Medium voltage plug

Standard output pressure range:

-	without pressure governor
0	with governor and air/gas proportional pressure
2	with governor and output pressure up to 20 mbar
3	with governor and output pressure up to 30 mbar
4	with governor and output pressure up to 40 mbar
5	with governor and output pressure up to 50 mbar
6	with governor and output pressure up to 60 mbar
8	with governor and output pressure up to 80 mbar
15	with governor and output pressure up to 150 mbar

Valve control:

0	shared
2	separate

CB	5065	/1	CT	F	SM	3	0
BASIC DESIGNATION				EXTENDED DESIGNATION			

GAS TRAINS

The burners are fitted with a butterfly valve to regulate the fuel, controlled by the main management module of burner through a high precision servomotor.
 Fuel can be supplied either from the right or left sides, on the basis of the application requirements.
 A maximum gas pressure switch stops the burner in case of excess pressure in the fuel line.
 The gas train can be selected to best fit system requirements depending on the fuel output and pressure in the supply line.
 The gas trains are with or without seal control.

MB "THREADED"

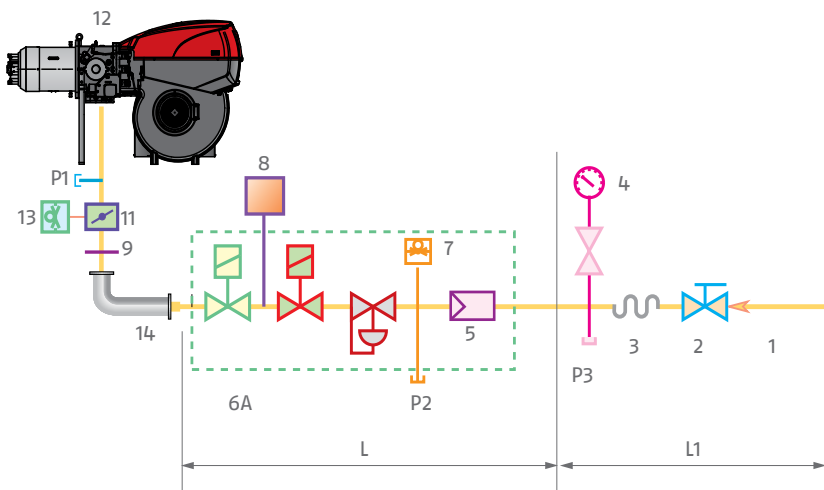

- | | |
|----|---|
| 1 | Gas input pipework |
| 2 | Manual valve |
| 3 | Anti-vibration joint |
| 4 | Pressure gauge with pushbutton cock |
| 5 | Filter |
| 6A | Includes: |
| | - filter |
| | - operation valve |
| | - safety valve |
| | - pressure adjuster |
| 7 | Minimum gas pressure switch |
| 8 | Leak detection device, supplied as an accessory or incorporated, based on the gas train code. |
| 9 | Gasket, for "flanged" versions only |
| 10 | Pressure adjuster |
| 11 | Gas adjuster butterfly valve |
| 12 | Burner |
| 13 | Maximum gas pressure switch |
| 14 | Gas train-burner adaptor, supplied separately |
| P1 | Combustion head pressure |
| P2 | Upstream pressure of valves |
| P3 | Upstream pressure of the filter |
| L | Gas train supplied separately, with the code given in the table. |
| L1 | Installer's responsibility |

MBC "THREADED"

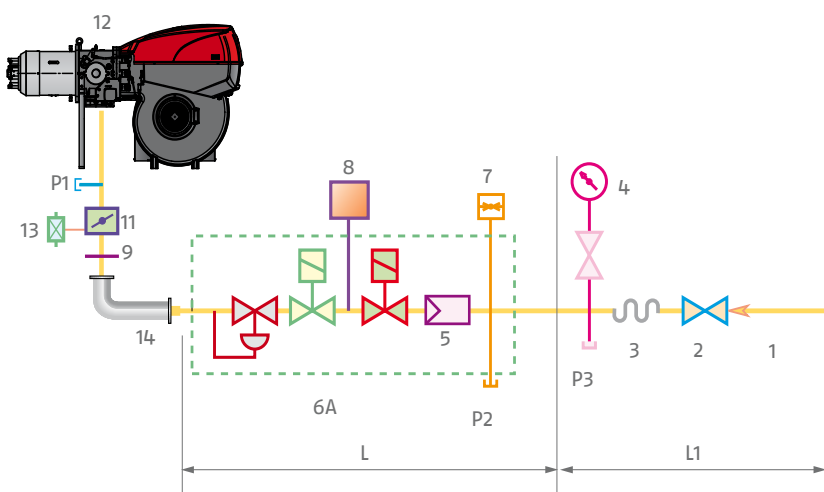

MBC "FLANGED"

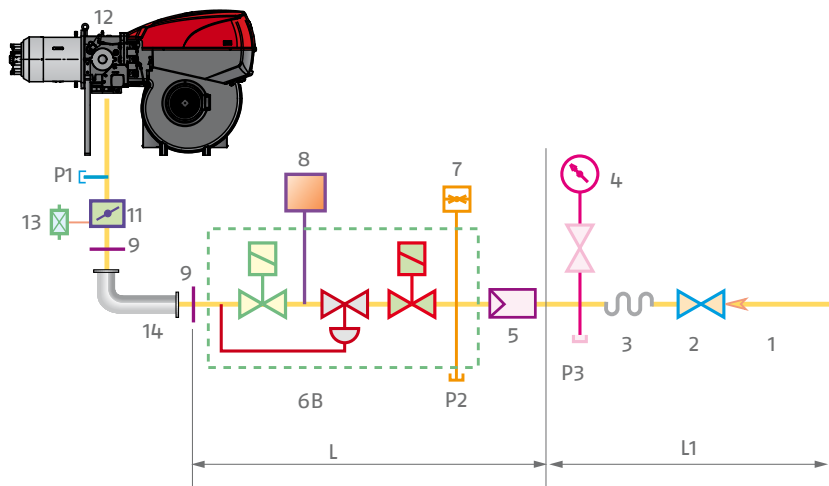

- 1 Gas input pipework
- 2 Manual valve
- 3 Anti-vibration joint
- 4 Pressure gauge with pushbutton cock
- 5 Filter
- 6B Includes:
 - operation valve
 - safety valve
 - pressure adjuster
- 6C Includes:
 - operation valve
 - safety valve
- 6D Includes:
 - operation valve
 - safety valve
- 7 Minimum gas pressure switch
- 8 Leak detection device, supplied as an accessory or incorporated, based on the gas train code.

CB "FLANGED OR THREADED"

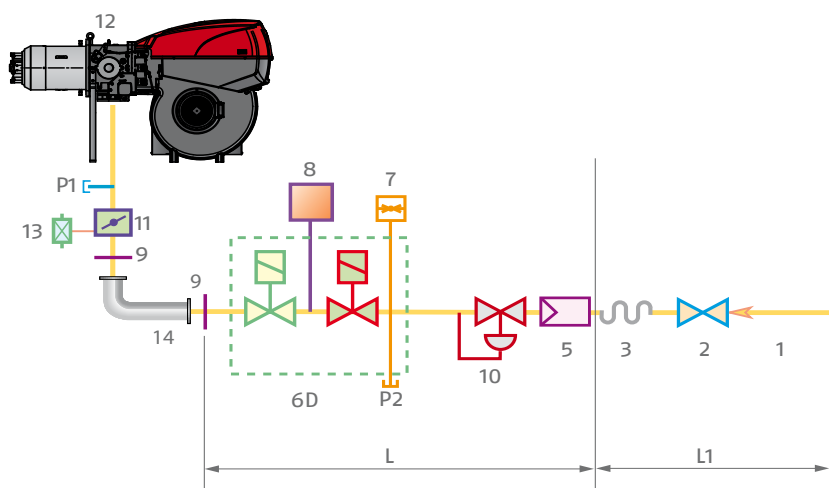

- 9 Gasket, for "flanged" versions only
- 10 Pressure adjuster
- 11 Gas adjuster butterfly valve
- 12 Burner
- 13 Maximum gas pressure switch
- 14 Gas train-burner adaptor, supplied separately
- P1 Combustion head pressure
- P2 Upstream pressure of valves
- P3 Upstream pressure of the filter
- L Gas train supplied separately, with the code given in the table

L1 Installer's responsibility

DMV "FLANGED OR THREADED"

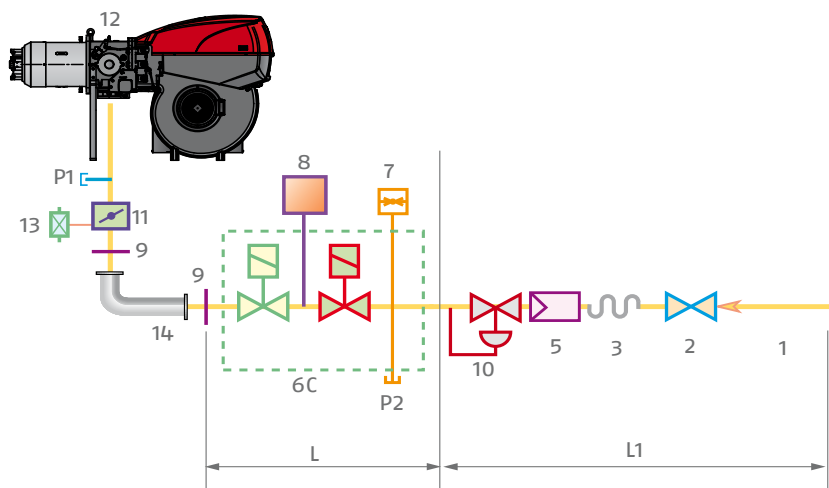

Gas trains are approved by standard EN 676 together with the burner.

The overall dimensions of the gas train depends on how they are constructed. The following table shows the maximum dimensions of the gas trains that can be fitted to RS 650-800-1000-1200/E-EV BLU burners, intake and outlet diameters and seal control if fitted.

The maximum gas pressure of gas train "MULTIBLOC" type is 360 mbar, and that one of gas train "COMPOSED" type is 500 mbar.

"MULTIBLOC" guarantees a range of pressure towards the burner from 4 to 60 mbar. For version DN 65 and DN 80 is from 20 to 40 mbar. For version DN 100 is from 40 to 80 mbar. The range of pressure in the "MULTIBLOC" with flange can be modified choosing the stabiliser spring (see gas train accessory).

The maximum gas pressure of gas train "CB" series is 500 mbar. "CB" gas train guarantees a range of pressure towards the burner from 10 to 30 mbar. The range of pressure can be modified choosing the stabilizer spring (see accessories).

The maximum gas pressure of gas train "DMV" series is 500 mbar. "DMV" gas train is supplied without pressure governor.

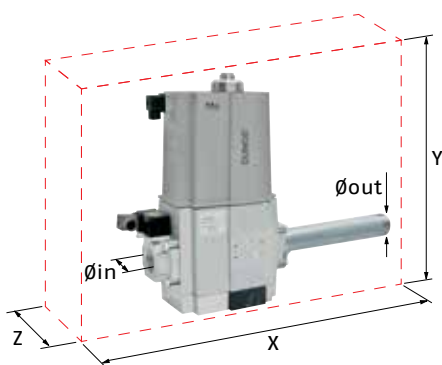

Example of gas train "MULTIBLOC" type without seal control (i.e. MBC 1200)

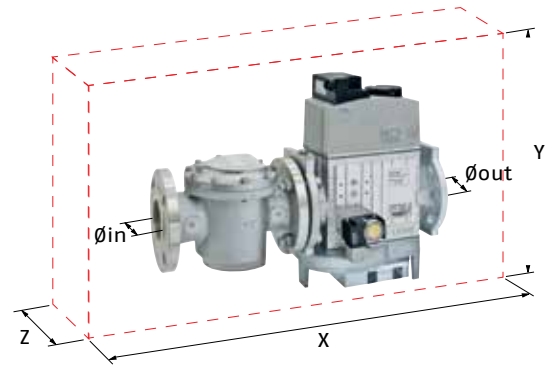

Example of gas train "COMPOSED" type without seal control (i.e. MBC 1900-3100-5000)



Example of gas train "CB" series with seal control

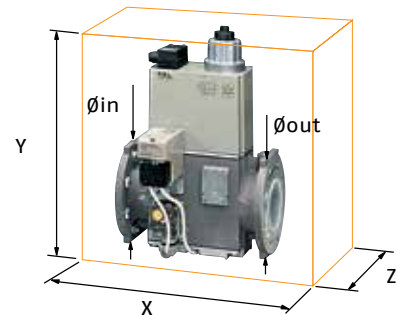

Example of gas train "DMV" series with seal control

GAS TRAIN						
MODEL	CODE	Ø in	Ø out	X mm	Y mm	Z mm
MB 415/1 - RT 30	3970180	Rp 1-1/2"	Rp 1-1/2"	523	250	100
MB 415/1 CT RT 30	3970198	Rp 1-1/2"	Rp 1-1/2"	523	250	229
MB 415/1 - RT 52	3970250	Rp 1-1/2"	Rp 1-1/2"	523	250	100
MB 415/1 CT RT 52	3970253	Rp 1-1/2"	Rp 1-1/2"	523	250	229
MB 415/1 RSM 30	3970232	Rp 1-1/2"	Rp 1-1/2"	523	250	100
MB 420/1 RT 30	3970181	Rp 2"	Rp 2"	523	289	100
MB 420/1 CT RT 30	3970182	Rp 2"	Rp 2"	523	289	229
MB 420/1 RT 52	3970257	Rp 2"	Rp 2"	523	289	100
MB 420/1 CT RT 52	3970252	Rp 2"	Rp 2"	523	289	229
MB 420/1 RSM 30	3970233	Rp 2"	Rp 2"	523	289	100
MB 420/1 CT RSM 30	3970234	Rp 2"	Rp 2"	523	289	229

GAS TRAIN						
MODEL	CODE	∅ in	∅ out	X mm	Y mm	Z mm
MBC 1200/1 - RSM 60	3970221	Rp 2"	Rp 2"	528	424	161
MBC 1200/1 CT RSM 60	3970225	Rp 2"	Rp 2"	528	424	290
MBC 1900/1 - FSM 40	3970222	DN 65	DN 65	613	430	237
MBC 1900/1 CT FSM 40	3970226	DN 65	DN 65	613	430	298
MBC 3100/1 - FSM 40	3970223	DN 80	DN 80	633	500	240
MBC 3100/1 CT FSM 40	3970227	DN 80	DN 80	633	500	319
MBC 5000/1 - FSM 80	3970224	DN 100	DN 100	733	576	280
MBC 5000/1 CT FSM 80	3970228	DN 100	DN 100	733	576	348

GAS TRAIN						
MODEL	CODE	∅ in	∅ out	X mm	Y mm	Z mm
CB 512/1 - RSM 30	3970145	Rp 1-1/2"	Rp 1-1/2"	891	261	245
CB 512/1 - CT RSM 30	20045589	Rp 1-1/2"	Rp 1-1/2"	891	261	245
CB 520/1 - RSM 30	3970146	Rp 2"	Rp 2"	986	328	255
CB 520/1 - CT RSM 30	3970160	Rp 2"	Rp 2"	986	328	255
CB 525/1 - RSM 30	20044659	Rp 2"	Rp 2"	1025	356	285
CB 525/1 - CT RSM 30	20044660	Rp 2"	Rp 2"	1025	356	285
CB 5065/1 - FSM 30	3970147	DN 65	DN 65	906	356	285
CB 5065/1 CT FSM 30	3970161	DN 65	DN 65	906	356	285
CB 5080/1 - FSM 30	3970148	DN 80	DN 80	934	416	285
CB 5080/1 CT FSM 30	3970162	DN 80	DN 80	934	416	285
CB 50100/1 - FSM 30	3970149	DN 100	DN 100	1054	501	350
CB 50100/1 CT FSM 30	3970163	DN 100	DN 100	1054	501	350
CB 50125/1 - FSM 30	20015871	DN 125	DN 125	1164	780	400
CB 50125/1 CT FSM 30	3970196	DN 125	DN 125	1164	780	400

GAS TRAIN						
MODEL	CODE	∅ in	∅ out	X mm	Y mm	Z mm
DMV 512/1 - RSM - 0	20043035	Rp 1-1/2"	Rp 1-1/2"	490	292	245
DMV 512/1 -CT RSM - 0	20043036	Rp 1-1/2"	Rp 1-1/2"	490	292	245
DMV 512/1 - CQ RSM - 2	20043037	Rp 1-1/2"	Rp 1-1/2"	490	292	245
DMV 520/1 - RSM - 0	20043038	Rp 2"	Rp 2"	490	292	255
DMV 520/1 CT RSM - 0	20043039	Rp 2"	Rp 2"	490	292	255
DMV 520/1 CQ RSM - 2	20043040	Rp 2"	Rp 2"	490	292	255
DMV 525/1 - RSM - 0	20043053	Rp 2"	Rp 2"	530	338	270
DMV 525/1 CT RSM - 0	20043054	Rp 2"	Rp 2"	530	338	270
DMV 525/1 CQ RSM - 2	20043055	Rp 2"	Rp 2"	530	338	270
DMV 5065/1 - FSM - 0	20043041	DN 65	DN 65	290	338	270
DMV 5065/1 CT FSM - 0	20043042	DN 65	DN 65	290	338	270
DMV 5065/1 CQ FSM - 2	20043043	DN 65	DN 65	290	338	270
DMV 5080/1 - FSM - 0	20043044	DN 80	DN 80	310	397	290
DMV 5080/1 CT FSM - 0	20043045	DN 80	DN 80	310	397	290
DMV 5080/1 CQ FSM - 2	20043046	DN 80	DN 80	310	397	290
DMV 50100/1 - FSM - 0	20043047	DN 100	DN 100	350	449	307
DMV 50100/1 CT FSM - 0	20043048	DN 100	DN 100	350	449	307
DMV 50100/1 CQ FSM - 2	20043049	DN 100	DN 100	350	449	307
DMV 50125/1 - FSM - 0	20043050	DN 125	DN 125	400	554	333
DMV 50125/1 CT FSM - 0	20043051	DN 125	DN 125	400	554	333
DMV 50125/1 CQ FSM - 2	20043052	DN 125	DN 125	400	554	333

Pressure Drop Diagram

The diagrams indicate the minimum pressure drop of the burners with the various gas trains that can be matched with them; at the value of these pressure drop add the combustion chamber pressure. The value thus calculated represents the minimum required input pressure to the gas train.

The minimum input gas pressure required is 15 mbar while burner operating. In particular, the pressure difference between gas train upstream and downstream has to remain always over pressure drop values indicated below.

RS 300/E-EV BLU (NATURAL GAS)

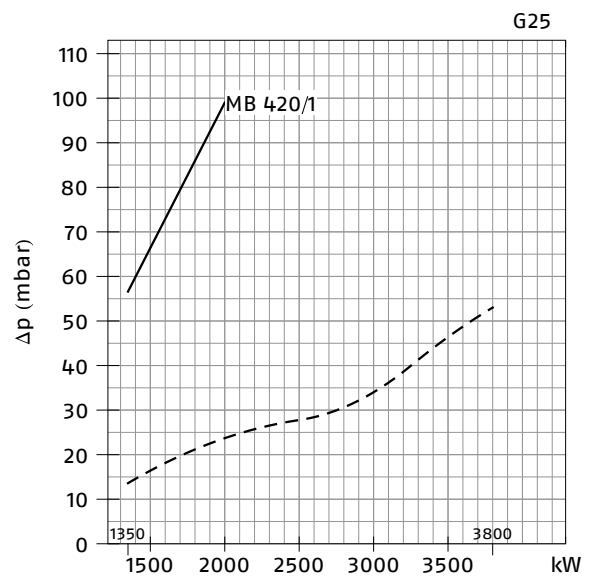
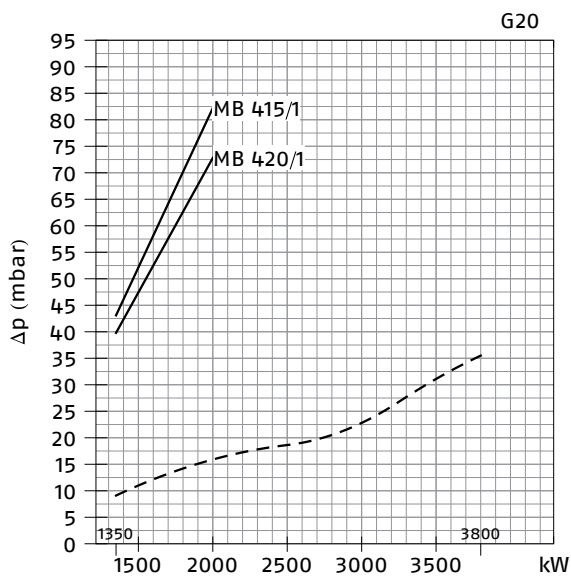

RS 300/E-EV BLU (NATURAL GAS)

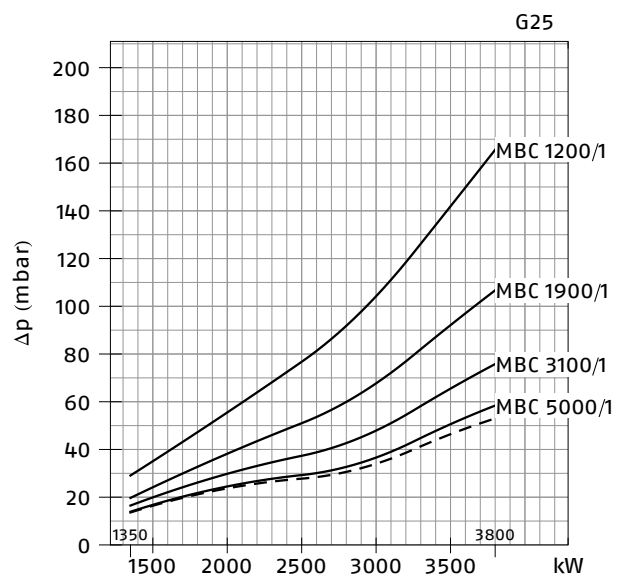
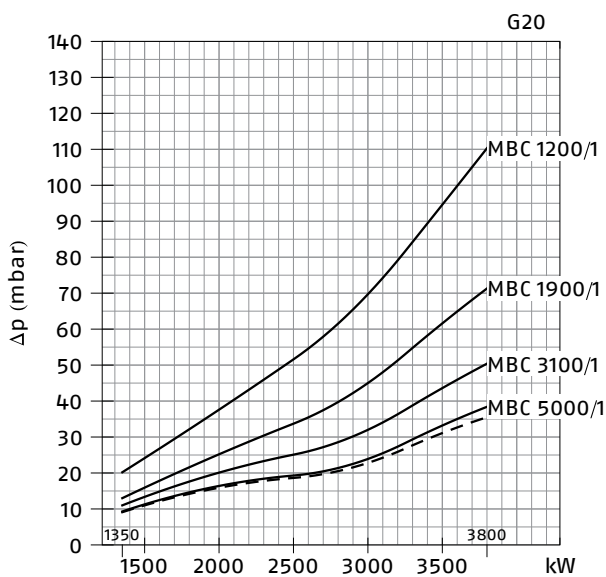

- Combustion head + gas butterfly valve + gas train
- - - Combustion head + gas butterfly valve

RS 300/E-EV BLU (NATURAL GAS)

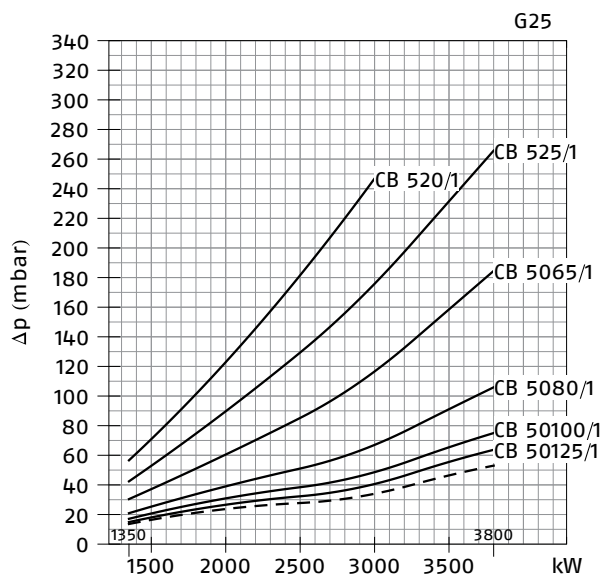
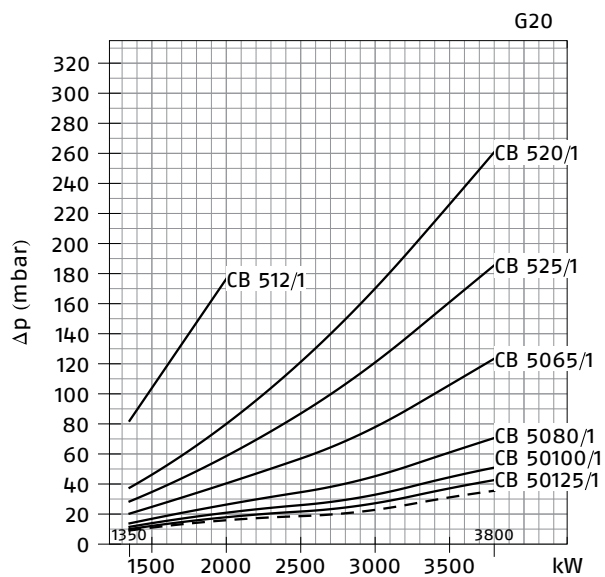

RS 300/E-EV BLU (NATURAL GAS)

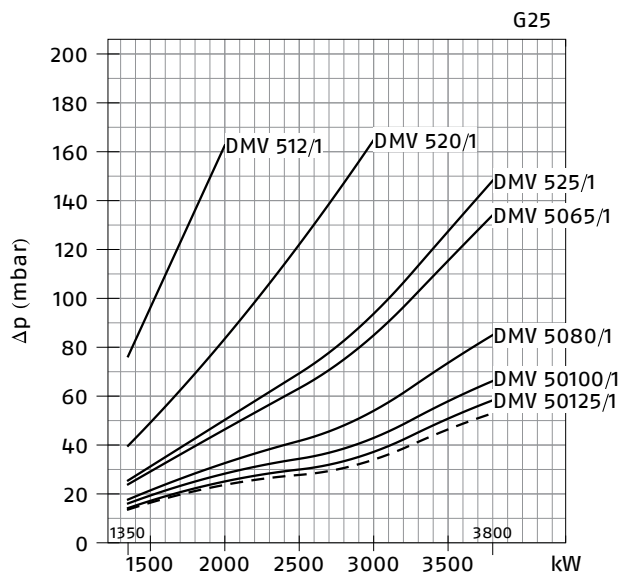
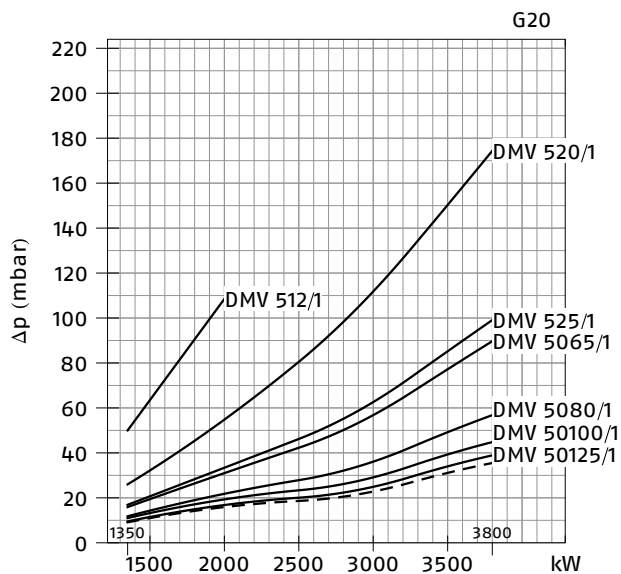

— Combustion head + gas butterfly valve + gas train
 - - - Combustion head + gas butterfly valve

RS 400/E-EV BLU (NATURAL GAS)

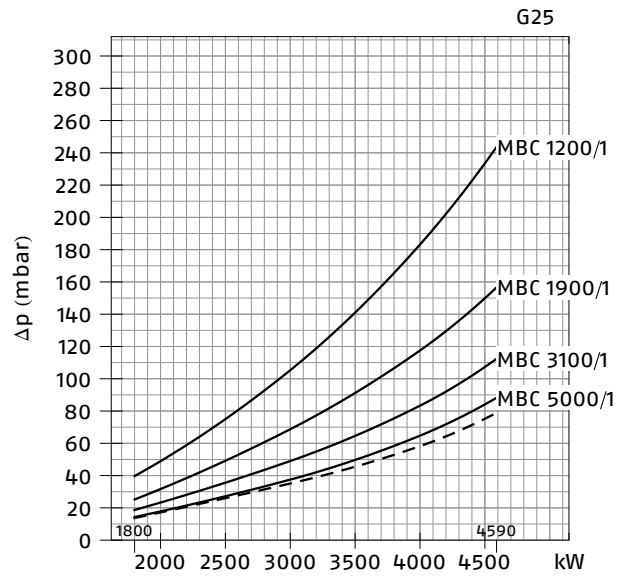
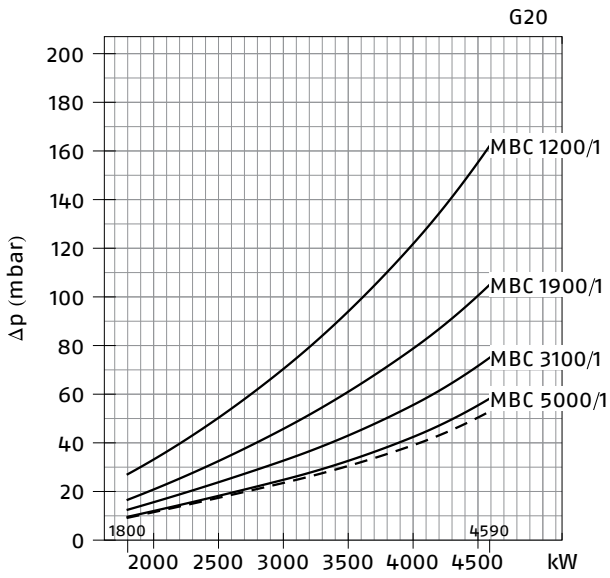

RS 400/E-EV BLU (NATURAL GAS)

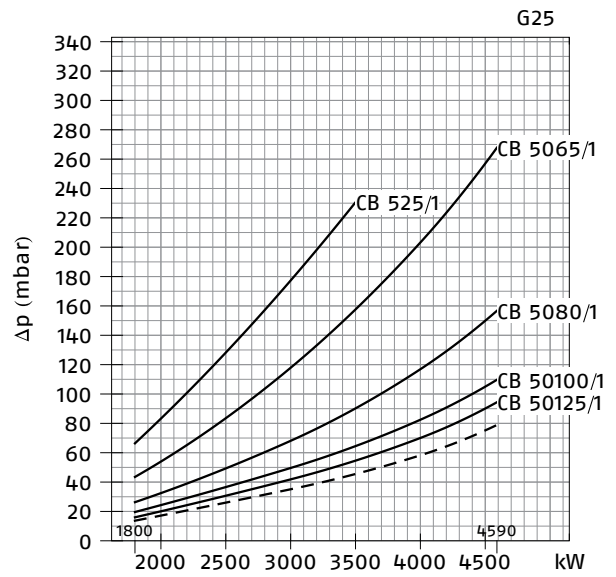
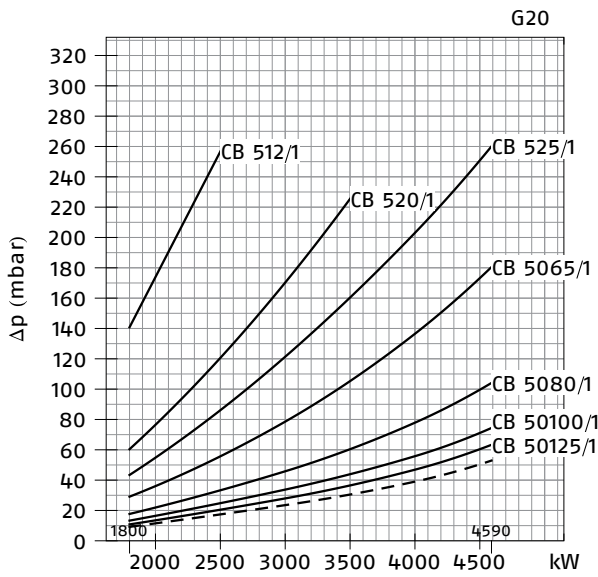

— Combustion head + gas butterfly valve + gas train
 - - - Combustion head + gas butterfly valve

RS 400/E-EV BLU (NATURAL GAS)

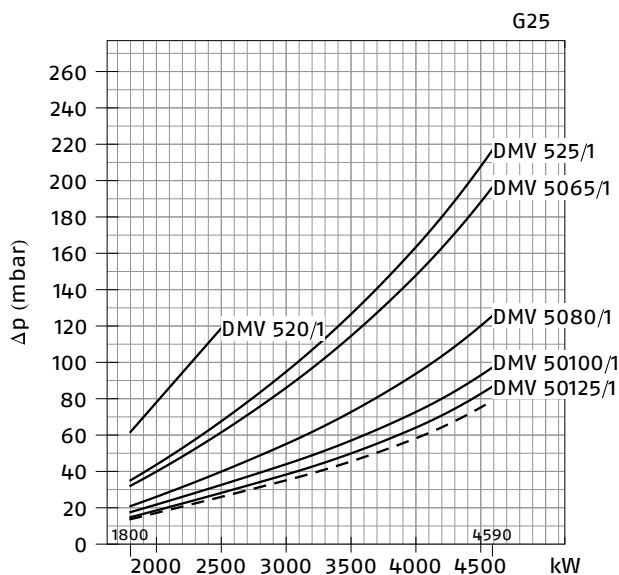
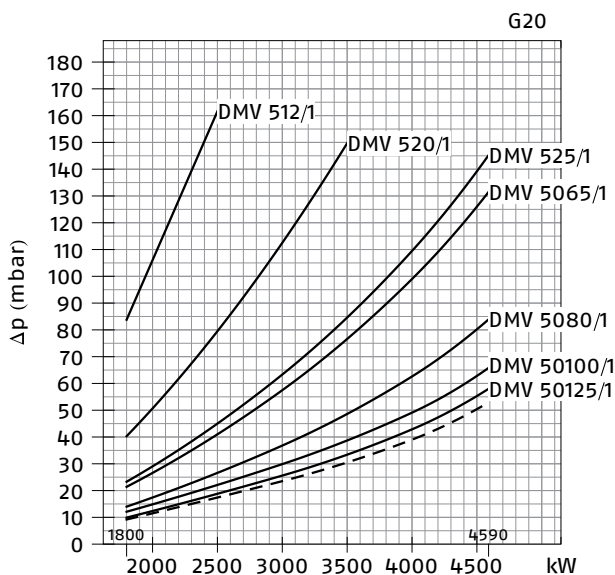

RS 500/E-EV BLU (NATURAL GAS)

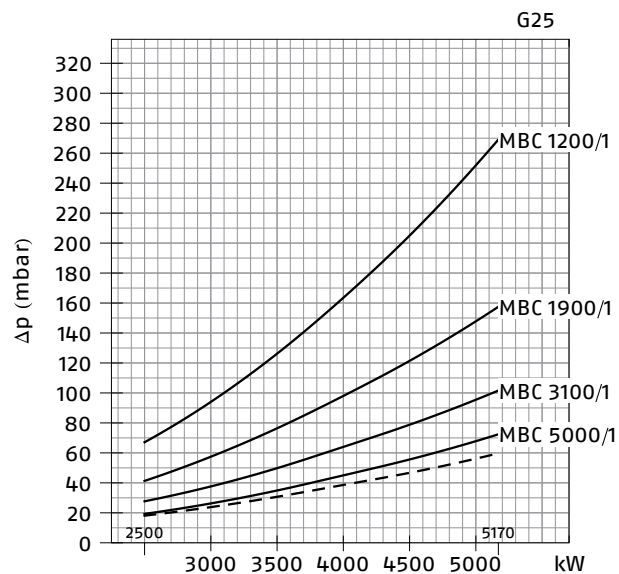
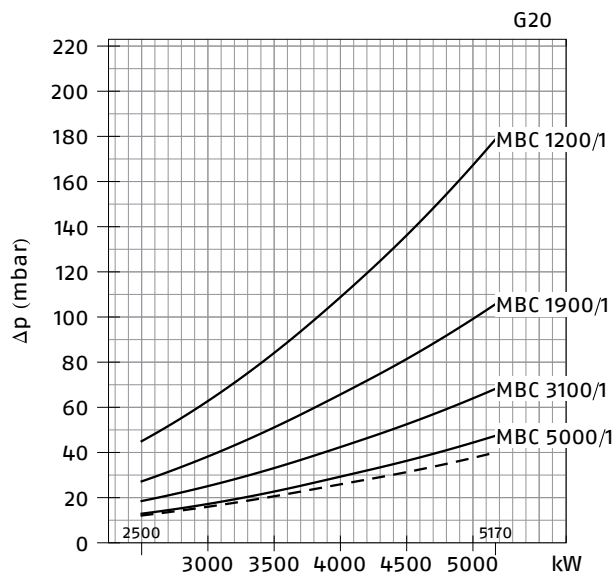

— Combustion head + gas butterfly valve + gas train
 - - - Combustion head + gas butterfly valve

RS 500/E-EV BLU (NATURAL GAS)

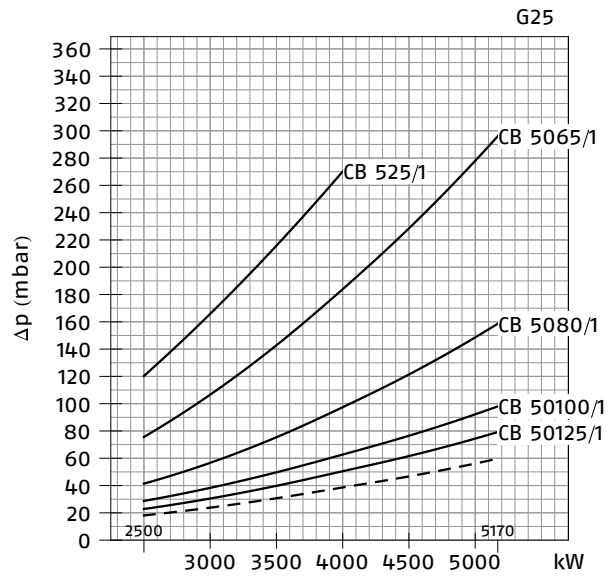
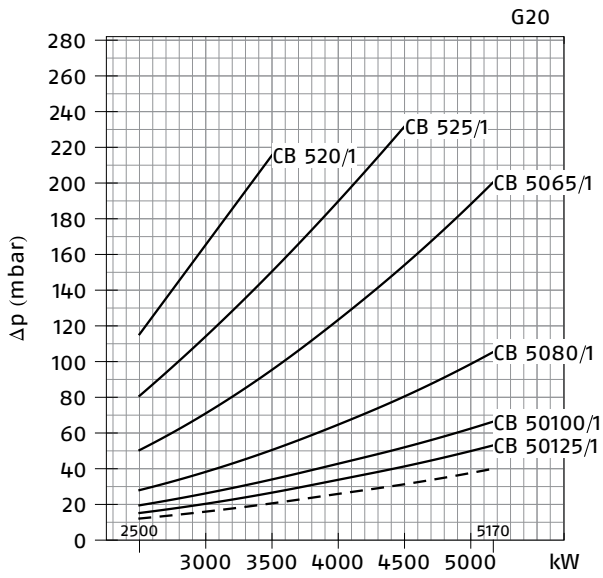

RS 500/E-EV BLU (NATURAL GAS)

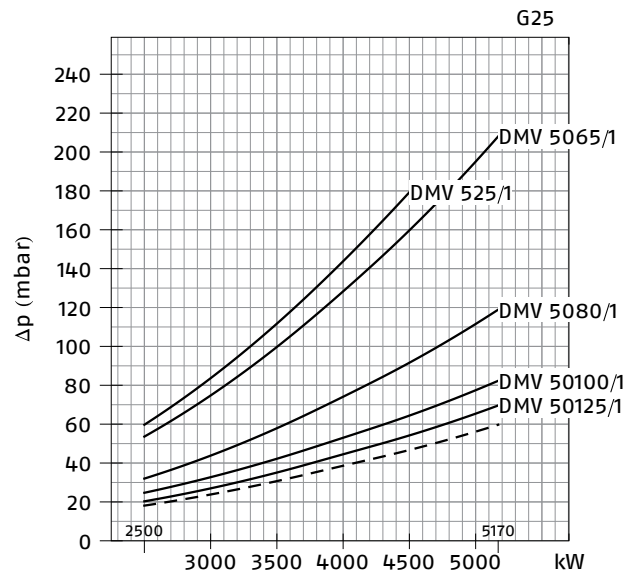
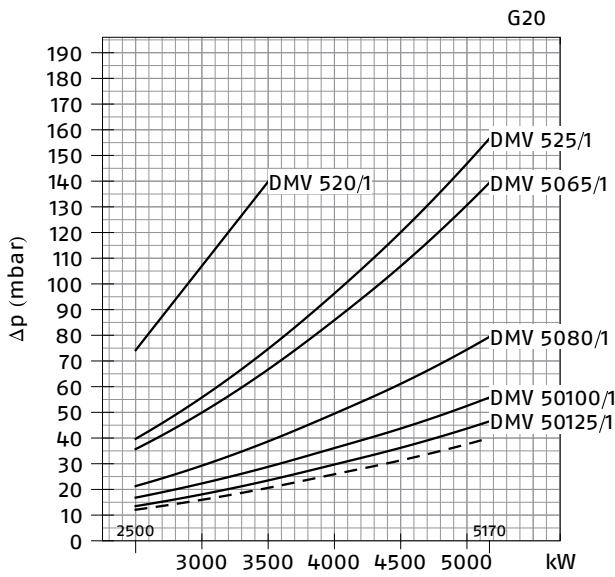

— Combustion head + gas butterfly valve + gas train
 - - - Combustion head + gas butterfly valve

RS 650/E-EV BLU (NATURAL GAS)

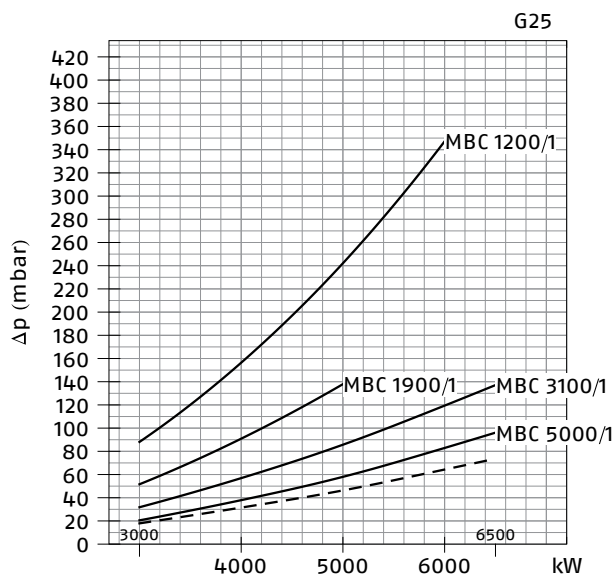
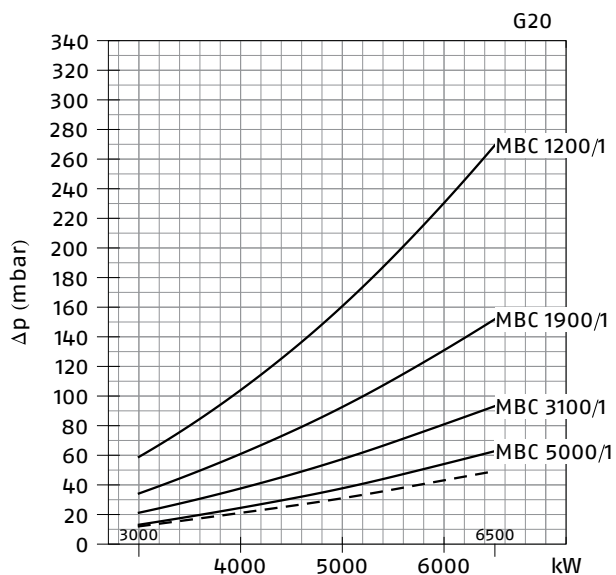

RS 650/E-EV BLU (NATURAL GAS)

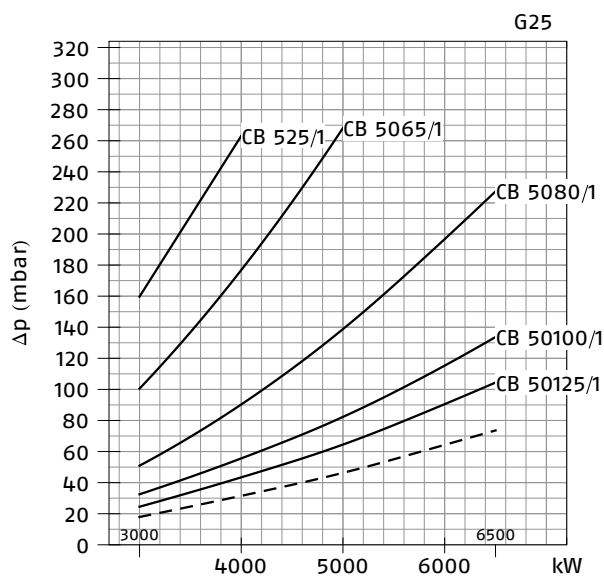
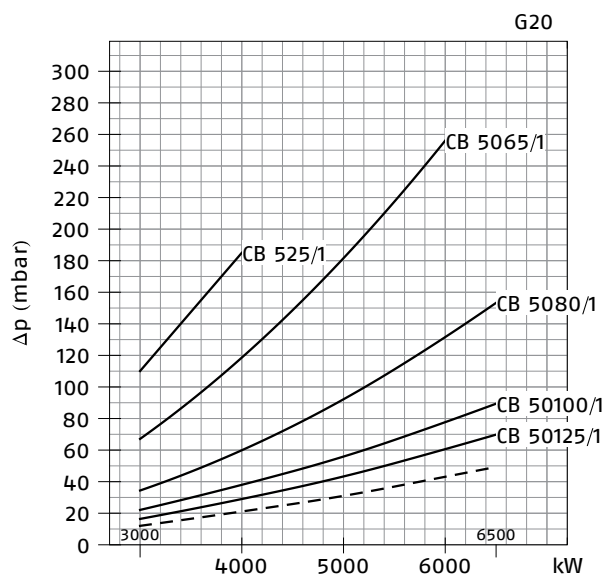

Combustion head + gas butterfly valve + gas train
 Combustion head + gas butterfly valve

RS 650/E-EV BLU (NATURAL GAS)

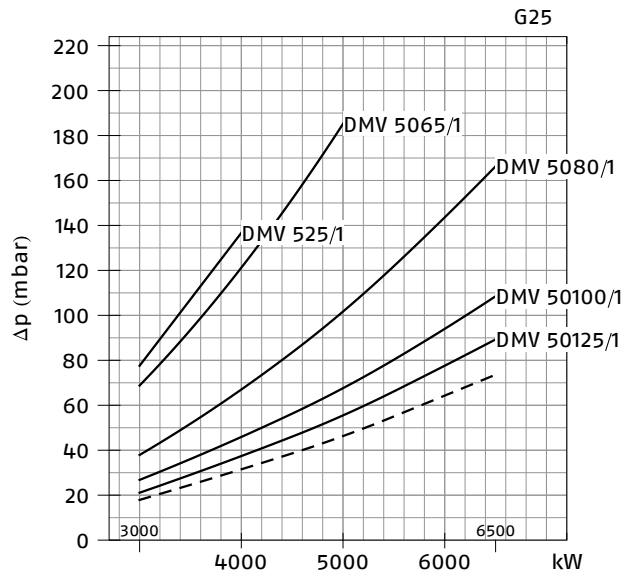
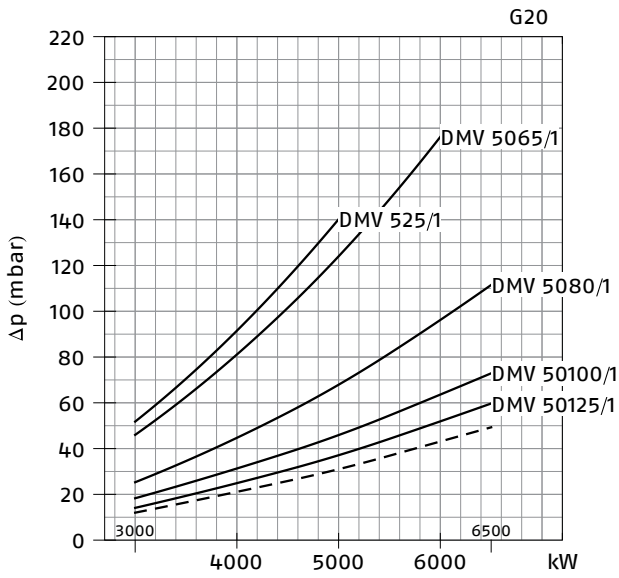

RS 800/E-EV BLU (NATURAL GAS)

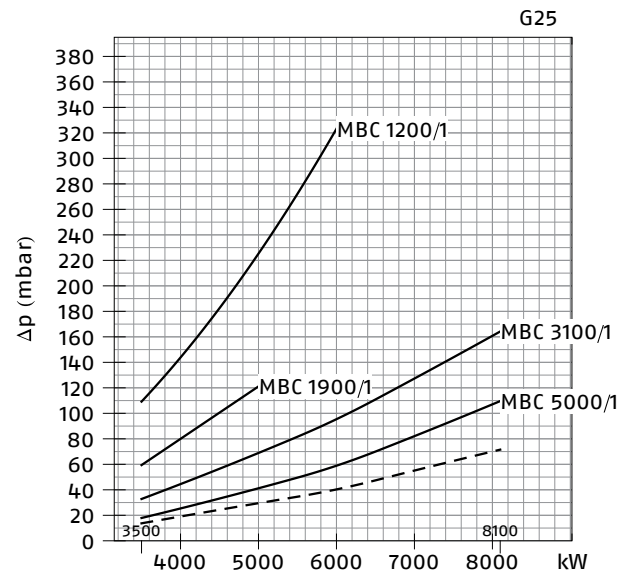
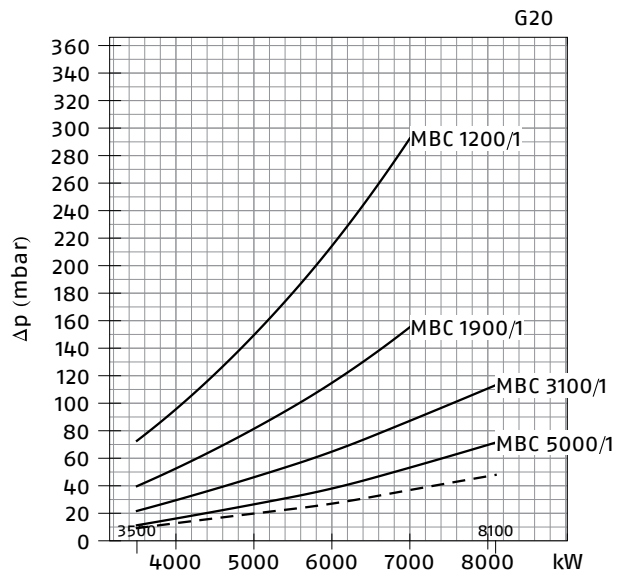

— Combustion head + gas butterfly valve + gas train
 - - - Combustion head + gas butterfly valve

RS 800/E-EV BLU (NATURAL GAS)

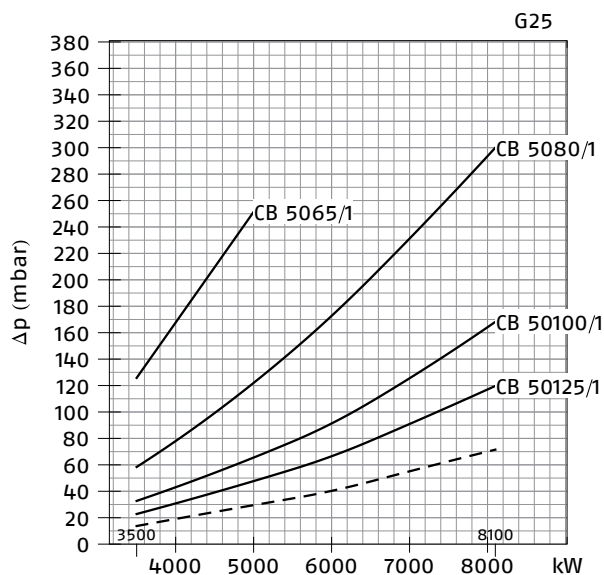
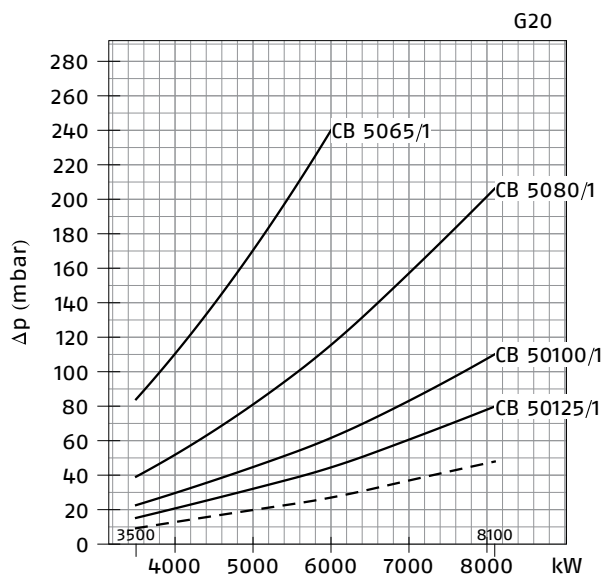

RS 800/E-EV BLU (NATURAL GAS)

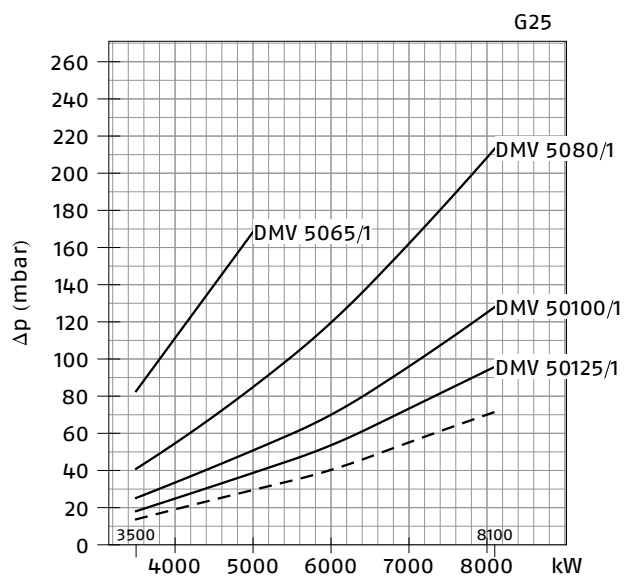
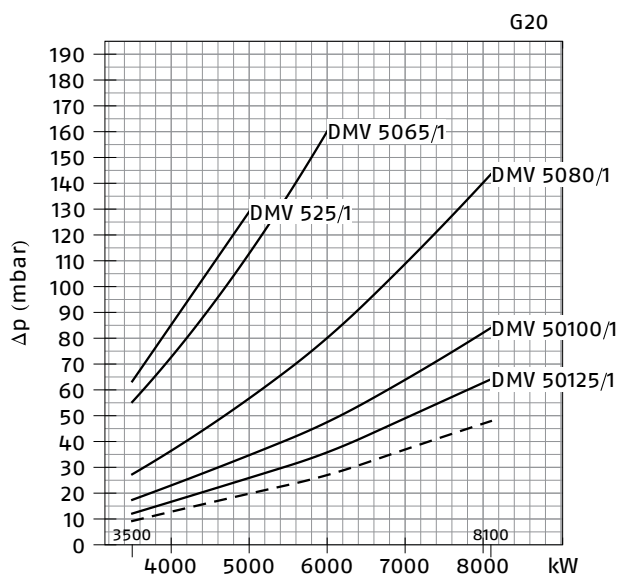

Combustion head + gas butterfly valve + gas train
 Combustion head + gas butterfly valve

RS 1000/E-EV BLU (NATURAL GAS)

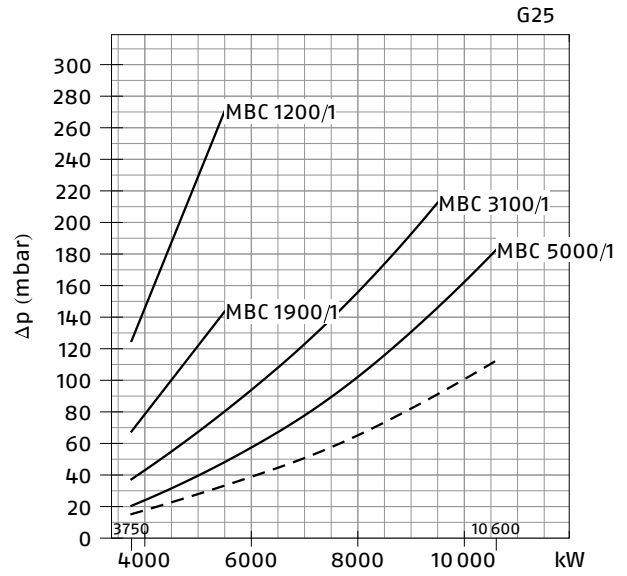
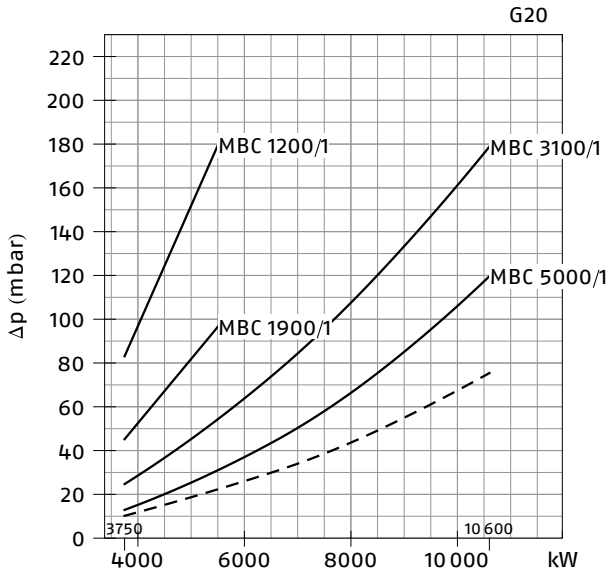

RS 1000/E-EV BLU (NATURAL GAS)

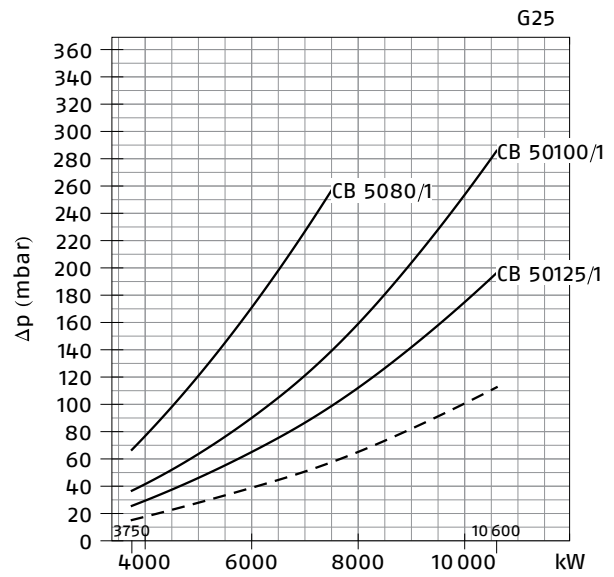
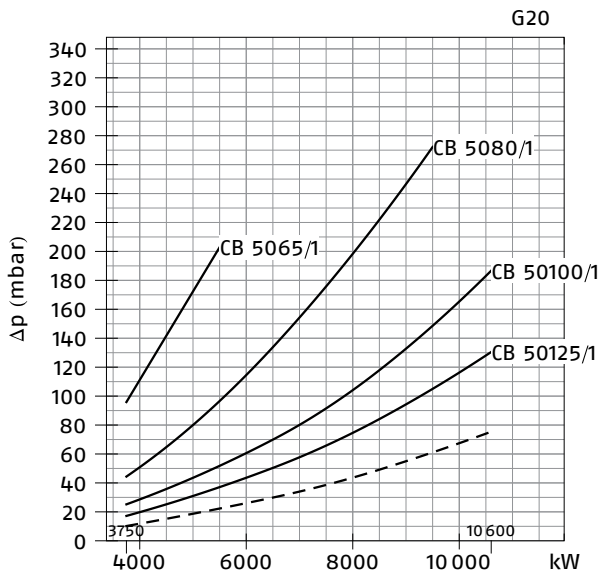

— Combustion head + gas butterfly valve + gas train
 - - - Combustion head + gas butterfly valve

RS 1000/E-EV BLU (NATURAL GAS)

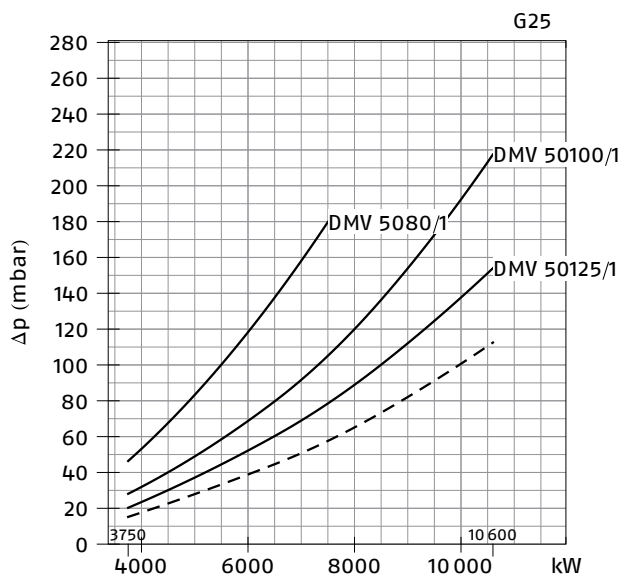
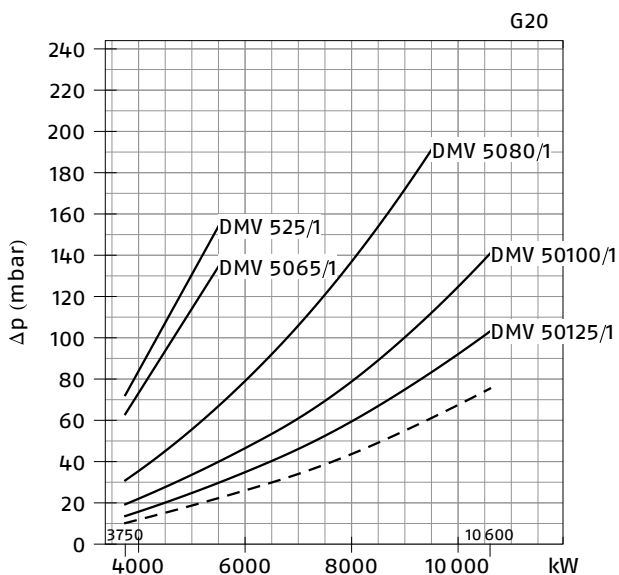

RS 1200/E-EV BLU (NATURAL GAS)

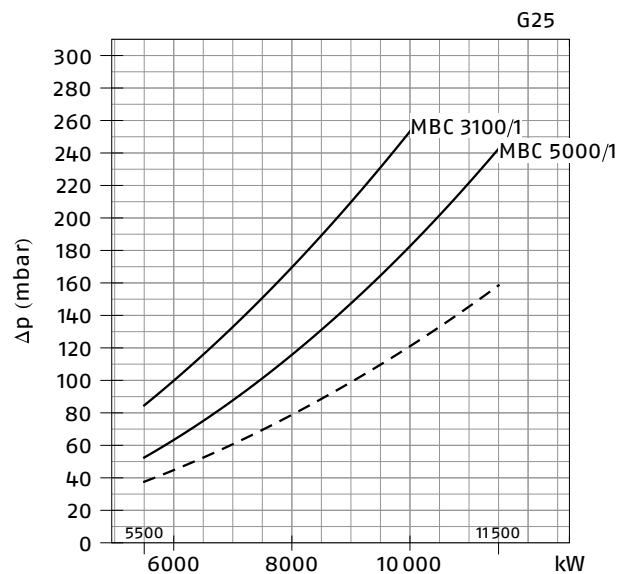
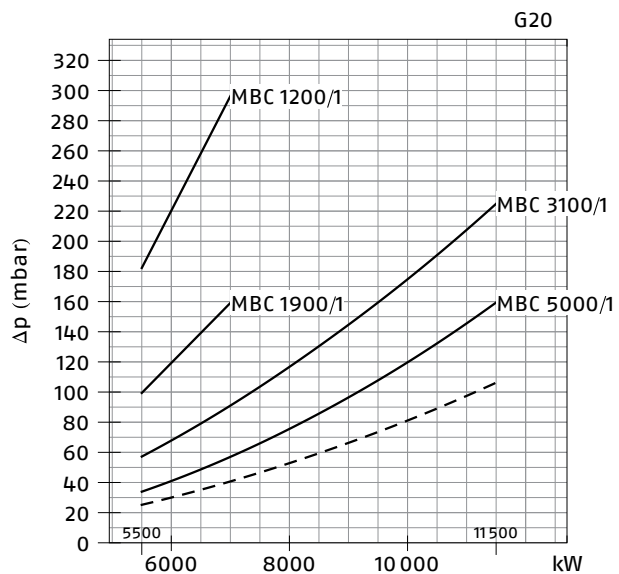

— Combustion head + gas butterfly valve + gas train
 - - - Combustion head + gas butterfly valve

RS 1200/E-EV BLU (NATURAL GAS)

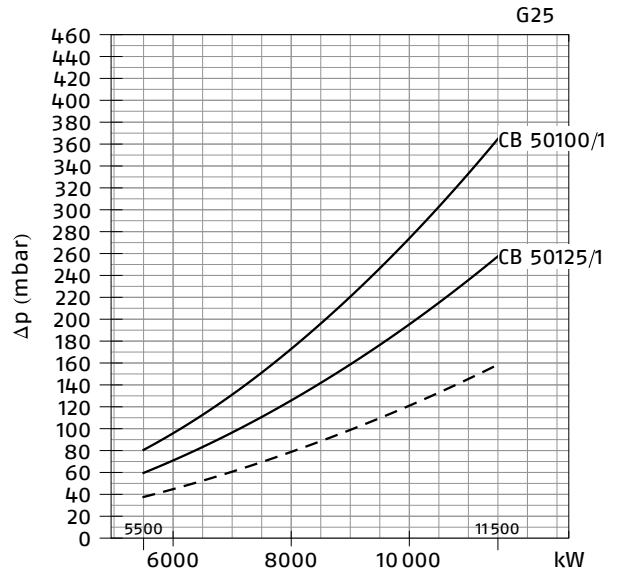
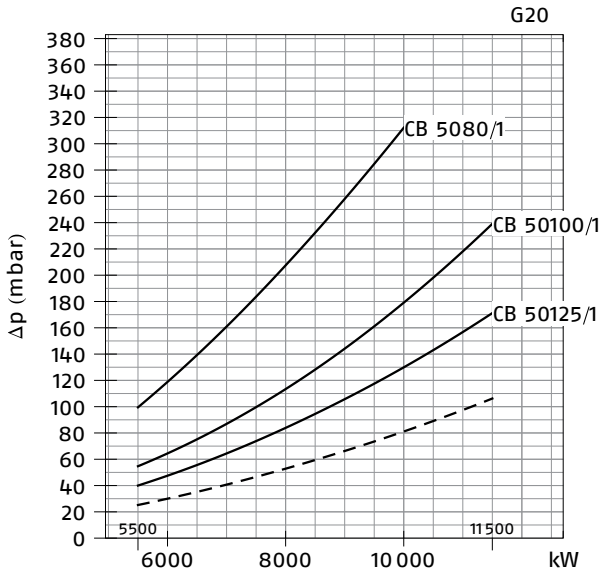

RS 1200/E-EV BLU (NATURAL GAS)

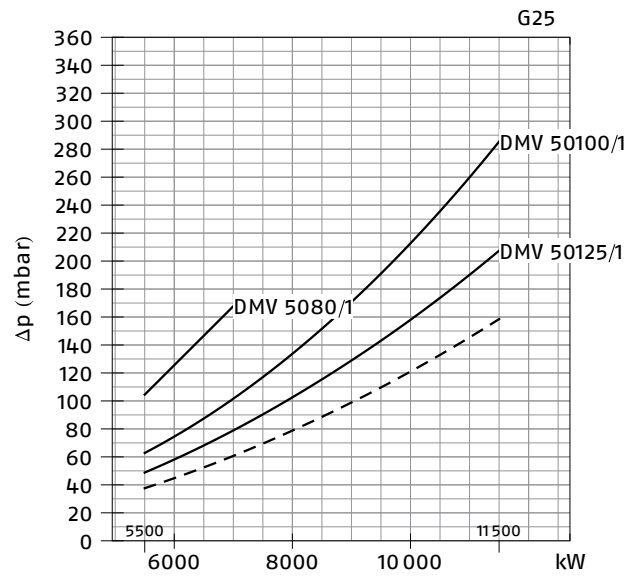
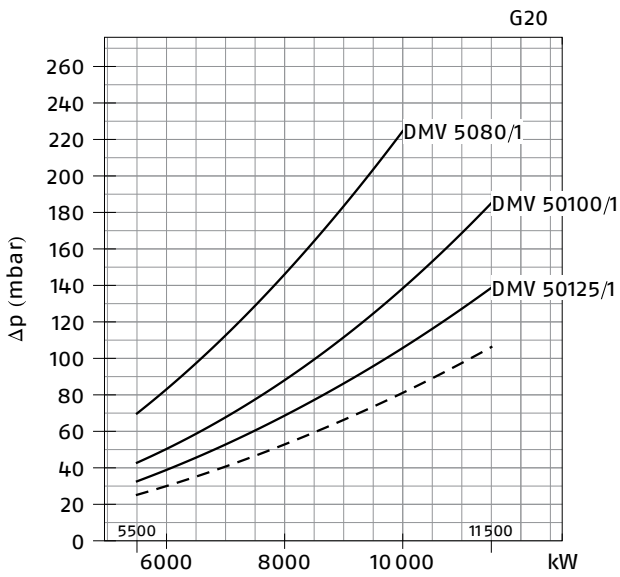

— Combustion head + gas butterfly valve + gas train
 - - - Combustion head + gas butterfly valve

GAS TRAIN		ADAPTER						
CODE	MODEL	CODE						
		RS 300	RS 400	RS 500	RS 650	RS 800	RS 1000	RS 1200
3970180	MB 415/1 - RT 30	20064220 + 20064169 / (20068062) ¹	●	●	●	●	●	●
3970198	MB 415/1 CT RT 30		●	●	●	●	●	●
3970250	MB 415/1 - RT 52		●	●	●	●	●	●
3970253	MB 415/1 CT RT 52		●	●	●	●	●	●
3970232	MB 415/1 - RSM 30		●	●	●	●	●	●
3970181	MB 420/1 - RT 30	20064169 / (20068062) ¹	●	●	●	●	●	●
3970182	MB 420/1 CT RT 30		●	●	●	●	●	●
3970257	MB 420/1 - RT 52		●	●	●	●	●	●
3970252	MB 420/1 CT RT 52		●	●	●	●	●	●
3970233	MB 420/1 - RSM 30		●	●	●	●	●	●
3970234	MB 420/1 CT RSM 30	●	●	●	●	●	●	
3970221	MBC 1200/1 - RSM 60	20064169 / (20068062) ¹					20066253 / (20068058) ¹	
3970225	MBC 1200/1 CT RSM 60							
3970222	MBC 1900/1 - FSM 40	20059330 / (20065924 + 20059330) ¹ / (3010221 + 20059331) ²					20066263 / (20065924 + 20066263) ¹	
3970226	MBC 1900/1 CT FSM 40							
3970223	MBC 3100/1 - FSM 40	20059331 / (20065937 + 20059331) ¹ / (3010222 + 20059331) ²					20066268 / (20065937 + 20066268) ¹	
3970227	MBC 3100/1 CT FSM 40							
3970224	MBC 5000/1 - FSM 80	20059332 / (20065960 + 20059332) ¹ / (3010223 + 20059331) ²					20066278 / (20065960 + 20066278) ¹	
3970228	MBC 5000/1 CT FSM 80							
3970145	CB 512/1 - RSM 30	20064220 + 20064169 /(20068062) ¹	●	●	●	●	●	●
20045589	CB 512/1 CT RSM 30		●	●	●	●	●	●
3970146	CB 520/1 - RSM 30	20064169 / (20068062) ¹	●	●	●	●	●	●
3970160	CB 520/1 CT RSM 30		●	●	●	●	●	●
20044659	CB 525/1 - RSM 30	20064169 / (20068062) ¹	●	●	●	●	●	●
20044660	CB 525/1 CT RSM 30		●	●	●	●	●	●
3970147	CB 5065/1 - FSM 30	20059330 / (20065924 + 20059330) ¹ / (3010221 + 20059331) ²					20066263 / (20065924 + 20066263) ¹	●
3970161	CB 5065/1 CT FSM 30							●
3970148	CB 5080/1 - FSM 30	20059331 / (20065937 + 20059331) ¹ / (3010222 + 20059331) ²					20066268 / (20065937 + 20066268) ¹	
3970162	CB 5080/1 CT FSM 30							
3970149	CB 50100/1 - FSM 30	20059332 / (20065960 + 20059332) ¹ / (3010223 + 20059331) ²					20066278 / (20065960 + 20066278) ¹	
3970163	CB 50100/1 CT FSM 30							
20015871	CB 50125/1 - FSM 30	20059333 / (20065968 + 20059333) ¹ / (3010224 + 20059331) ²					20066284 / (20065968 + 20066284) ¹	
3970196	CB 50125/1 CT FSM 30							

GAS TRAIN		ADAPTER						
CODE	MODEL	CODE						
		RS 300	RS 400	RS 500	RS 650	RS 800	RS 1000	RS 1200
20043035	DMV 512/1 - RSM -0	20064220 + 20064169 / (20068062) ¹		●	●	●	●	●
20043036	DMV 512/1 CT RSM -0			●	●	●	●	●
20043037	DMV 512/1 CQ RSM -2			●	●	●	●	●
20043038	DMV 520/1 - RSM -0	20064169 / (20068062) ¹			●	●	●	●
20043039	DMV 520/1 CT RSM -0				●	●	●	●
20043040	DMV 520/1 CQ RSM -2				●	●	●	●
20043053	DMV 525/1 - RSM -0	20064169 / (20068062) ¹						●
20043054	DMV 525/1 CT RSM -0						20066253 / (20068058) ¹	●
20043055	DMV 525/1 CQ RSM -2							●
20043041	DMV 5065/1 - FSM -0	20059330 / (20065924 + 20059330) ¹ / (3010221 + 20059331) ²						●
20043042	DMV 5065/1 CT FSM -0						20066263 / (20065924 + 20066263) ¹	●
20043043	DMV 5065/1 CQ FSM -2							●
20043044	DMV 5080/1 - FSM -0	20059331 / (20065937 + 20059331) ¹ / (3010222 + 20059331) ²						
20043045	DMV 5080/1 CT FSM -0						20066268 / (20065937 + 20066268) ¹	
20043046	DMV 5080/1 CQ FSM -2							
20043047	DMV 50100/1 - FSM -0	20059332 / (20065960 + 20059332) ¹ / (3010223 + 20059331) ²						
20043048	DMV 50100/1 CT FSM -0						20066278 / (20065960 + 20066278) ¹	
20043049	DMV 50100/1 CQ FSM -2							
20043050	DMV 50125/1 - FSM -0	20059333 / (20065968 + 20059333) ¹ / (3010224 + 20059331) ²						
20043051	DMV 50125/1 CT FSM -0						20066284 / (20065968 + 20066284) ¹	
20043052	DMV 50125/1 CQ FSM -2							

Key to layout

● Not available

1) To be used with gas train and burner opening on the left (fan motor side).

2) To be used with gas train on the left (fan motor side) and burner opening on the right.

Selecting the Fuel Supply lines

The following diagram enables pressure drop in a pre-existing gas line to be calculated and to select the correct gas train.

The diagram can also be used to select a new gas line when fuel output and pipe length are known. The pipe diameter is selected on the basis of the desired pressure drop. The diagram uses methane gas as reference; if another gas is used, conversion coefficient and a simple formula (on the diagram) transform the gas output to a methane equivalent (refer to figure A). Please note that the gas train dimensions must take into account the back pressure of the combustion chamber during operations.

Control of the pressure drop in an existing gas line or selecting a new gas supply line.

The methane output equivalent is determined by the formula fig. A on the diagram and the conversion coefficient.

Once the equivalent output has been determined on the delivery scale (\dot{V}), shown at the top of the diagram, move vertically downwards until you cross the line that represents the pipe diameter; at this point, move horizontally to the left until you meet the line that represents the pipe length.

Once this point is established you can verify, by moving vertically downwards, the pipe pressure drop of on the bottom scale below (mbar).

By subtracting this value from the pressure measured on the gas meter, the correct pressure value will be found for the choice of gas train.

Example: - gas used G25
 - gas output 9.51 mc/h
 - pressure at the gas meter 20 mbar
 - gas line length 15 m
 - conversion coefficient 0.62
 (see figure A)

- equivalent methane output $\dot{V} = \left[\frac{9.51}{0.62} \right] = 15.34$ mc/h

- once the value of 15.34 has been identified on the output scale (\dot{V}), moving vertically downwards you cross the line that represents 1" 1/4 (the chosen diameter for the piping);

- from this point, move horizontally to the left until you meet the line that represents the length of 15 m of the piping;

- move vertically downwards to determine a value of 1.4 mbar in the pressure drop bottom scale;

- subtract the determined pressure drop from the meter pressure, the correct pressure level will be found for the choice of gas train;

- correct pressure = (20-1.4) = 18.6 mbar

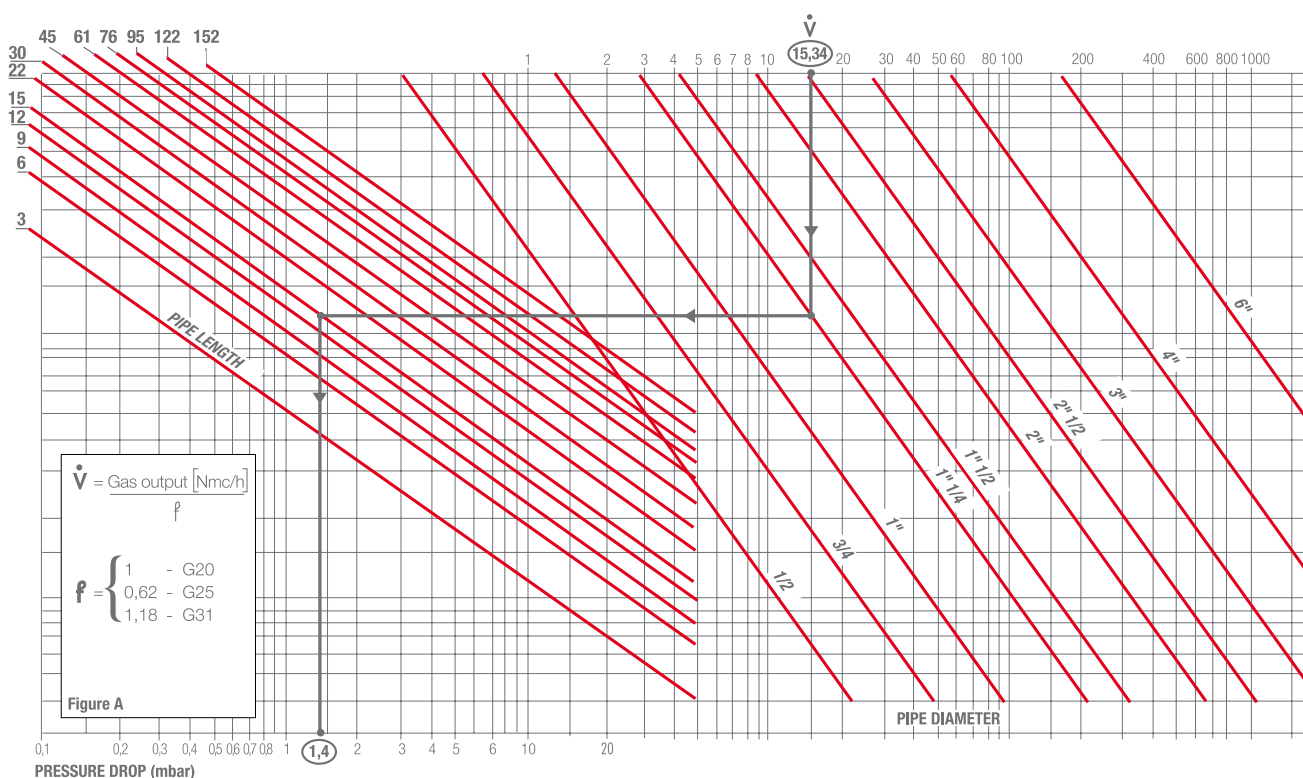

Ventilation

The ventilation unit comes with a sound proofing radial system. The RS 300-400-500-650-800-1000-1200/E-EV BLU burner models are fitted with fans, which give excellent performance and are fitted in line with the combustion head. The air flow and sound-deadening materials used in the construction are designed to reduce sound emissions to the minimum and guarantee high levels of performance in terms of output and air pressure. A high precision servomotor through the main management module installed on each burner of RS/E-EV series, controls the air dampers position constantly, guaranteeing an optimal fuel-air mix. The RS/EV is supplied with the "inverter" configuration, which means they are fitted with a device for varying the amount of combustion air through a variable speed action of the fan motor. The burner works at reduced speed, with further benefits in terms of sound emissions, especially during the night when the perception threshold is lower as well decreased power consumption.



Example of the RS 1000-1200/E-EV BLU sound proofing system.

Combustion Head

The innovative combustion head adjustment system ensures perfect movement during modulation as well as reducing noise and pollutants. Simple adjustment of the combustion head allows to adapt internal geometry of the head to the output of the burner. The same adjustment servomotor for the air damper also varies, depending on the required output, the setting of the combustion head, through a simple lever. This system guarantees excellent mix on all firing rates range.

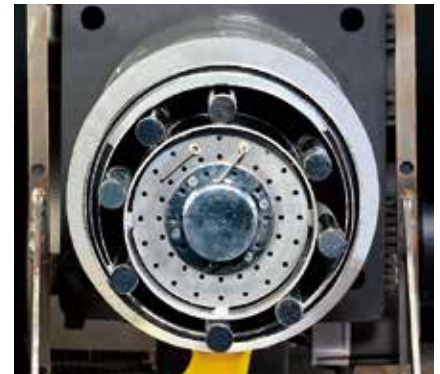

Example of RS/E-EV BLU burner combustion head.

DIMENSIONS OF THE FLAME

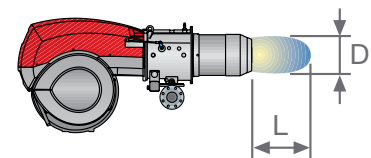
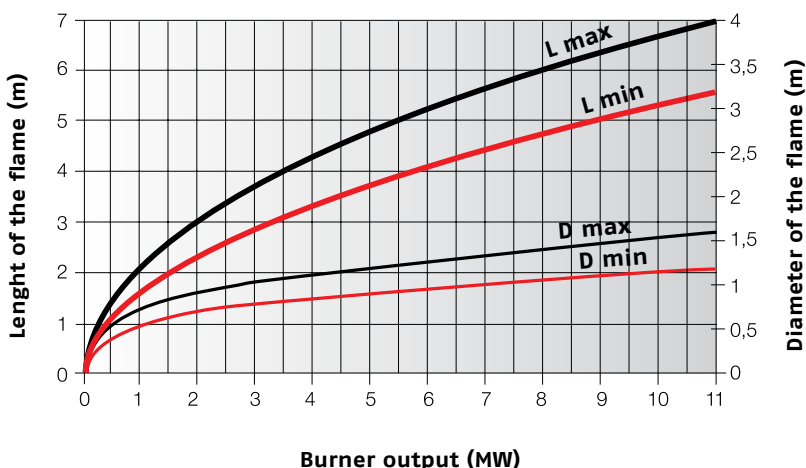

Example:
 Burner thermal output = 6000 kW;
 L flame (m) = 4,7 m (medium value);
 D flame (m) = 1,2 m (medium value)

Safe and Green

The RS/E-EV BLU series reduces polluting emissions with its exclusive design which optimises air/fuel mixture.

The gas in the combustion head is distributed through openings which are perpendicular to the air flow; part of the fuel is injected directly into the centre of the flame.

This results in low flame temperature combustion to prevent the formation of NO. Gradual and progressive combustion throughout the flame prevents areas of high oxidation inside the flame. Emissions are further reduced by the re-circulation of combustion gases due to the high velocity of air leaving the combustion head. Pollution levels are below even the most severe standards requirement.

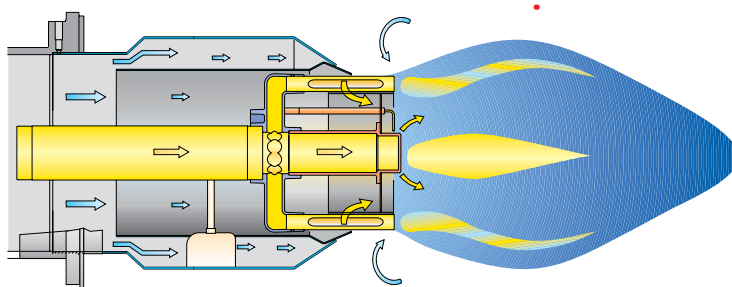

Operation

BURNER OPERATION MODE

Each RS/E - EV BLU series burner is equipped with an electronic microprocessor management panel, which controls the air damper servomotor as well the fuel servomotors.

Hysteresis is prevented by the precise control of the two servomotors and the software link by can - bus.

The high precision regulation is due to the absence of mechanical clearance normally found in mechanical regulation cams on traditional modulating burners.

For the burner commissioning it is necessary to use the AZL unit display.

It must be ordered separately for RS 300-400-500-650-800/E models, while for /EV models and RS 1000-1200/E it is included.

In the RS 300-400-500-650-800/E series burner the standard working is two stage progressive and the PID regulator, to control the boiler temperature or pressure, is available as accessory.

In the RS/EV series burner and RS 1000-1200/E the PID regulator to control the boiler temperature or pressure is included in LMV51.1 and LMV52. The burner can work for a long time on intermediate output settings (see picture A).

Variable speed drive control (VSD) and Oxygen control are obtained by installation of a special kit. The display operating unit (AZL) is already on board.

The display and operating unit (AZL) shows all operational parameters in real time, so as to keep a constant check on the burner:

- servomotor angle
- required set-point and actual set-point
- fuel consumption (RS/EV)
- smoke and environmental temperature (RS/EV)
- O₂ value (RS/EV)
- error checking, self diagnostic fault analysis.



"Modulating" operation

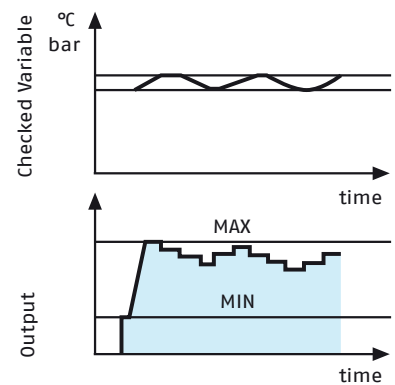

Picture A

CONTROL BOX MANAGEMENT TABLE

FUNCTION	LMV 51.0	LMV 51.1	LMV 52.2
Intermittent operation	●	●	●
Continuous operation	●	●	●
Intermittent operation flame detector	Ionisation Probe	Infrared detector	Ionisation Probe / Infrared detector
Continuous operation flame detector	Ionisation Probe / Infrared detector	Infrared detector	Ionisation Probe / Infrared detector
Numbers of regulating step-per actuators	4	4	5
Variable Speed Drive (VSD)	-	-	○
Input O ₂ probe	-	-	○
Built in O ₂ regulator	-	-	○
Single fuel operation	●	●	●
Double fuel operation (different timing for oil and gas)	●	●	●
Gas valve proving system	●	●	●
Built in temperature pressure PID regulator	○	●	●
External analog modulation	on demand	●	●
Analog 4÷20 mA output load signal	●	on demand	●
Efficiency Indication	-	-	○
External e-Bus Interface (AZL)	○	●	●
Commissioning PC Interface (AZL)	○	○	○
Commissioning Interface Display (AZL)	○	●	●

Control box management version table

Version	RS 300/E	RS 1000/E	RS/EV
RS 400/E			
RS 500/E			
RS 650/E			
RS 800/E			
LMV 51.0	●		
LMV 51.1		●	
LMV 52.2			●

- Included in supply
- As accessory

FAN SPEED CONTROL (ON DEMAND)

The inverter device fitted to the RS/EV series burner acts on the electrical supply frequency of the fan motor to adjust the air flow through the motor speed variation.

The main advantages of speed control:

- lower sound emissions
- electric power saving.

The fan motor supplies just the necessary air flow, thus reducing sound emissions and avoiding energy loss due to the air damper regulation mechanism. The inverter technology can save up to 35% of the energy costs.

A safety device to verify the correct speed of the motor is mounted on the air suction circuit of the burner.

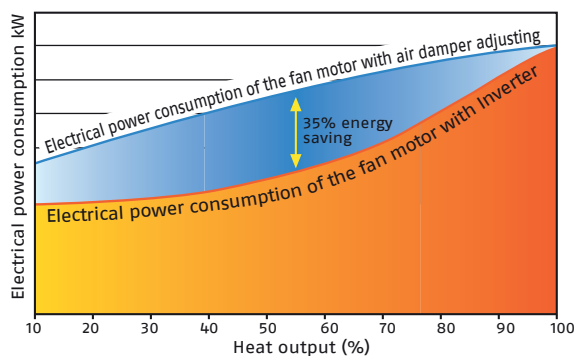

BURNER MANAGEMENT SYSTEM

The new electronic cam is a microprocessor based burner management system with matching system components for the control and supervision of forced draft burners.

The system components are interconnected via a bus system.

Communication between the individual bus users takes place via a reliable system-based data bus.

All safety-related digital outputs of the system are permanently monitored via a contact feedback network.

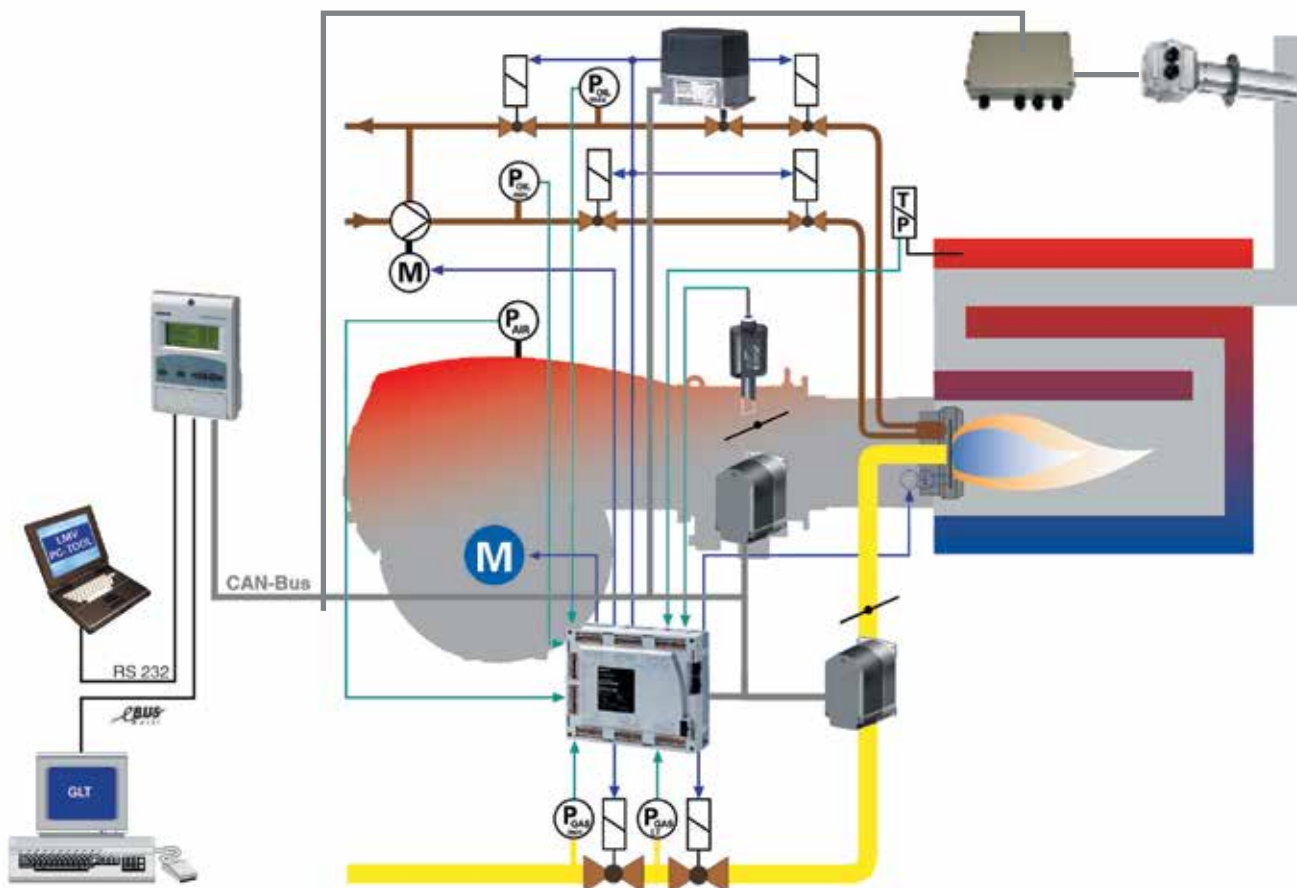

Example of burner management system in dual fuel burner configuration

ELECTRONIC CAM PLATFORM

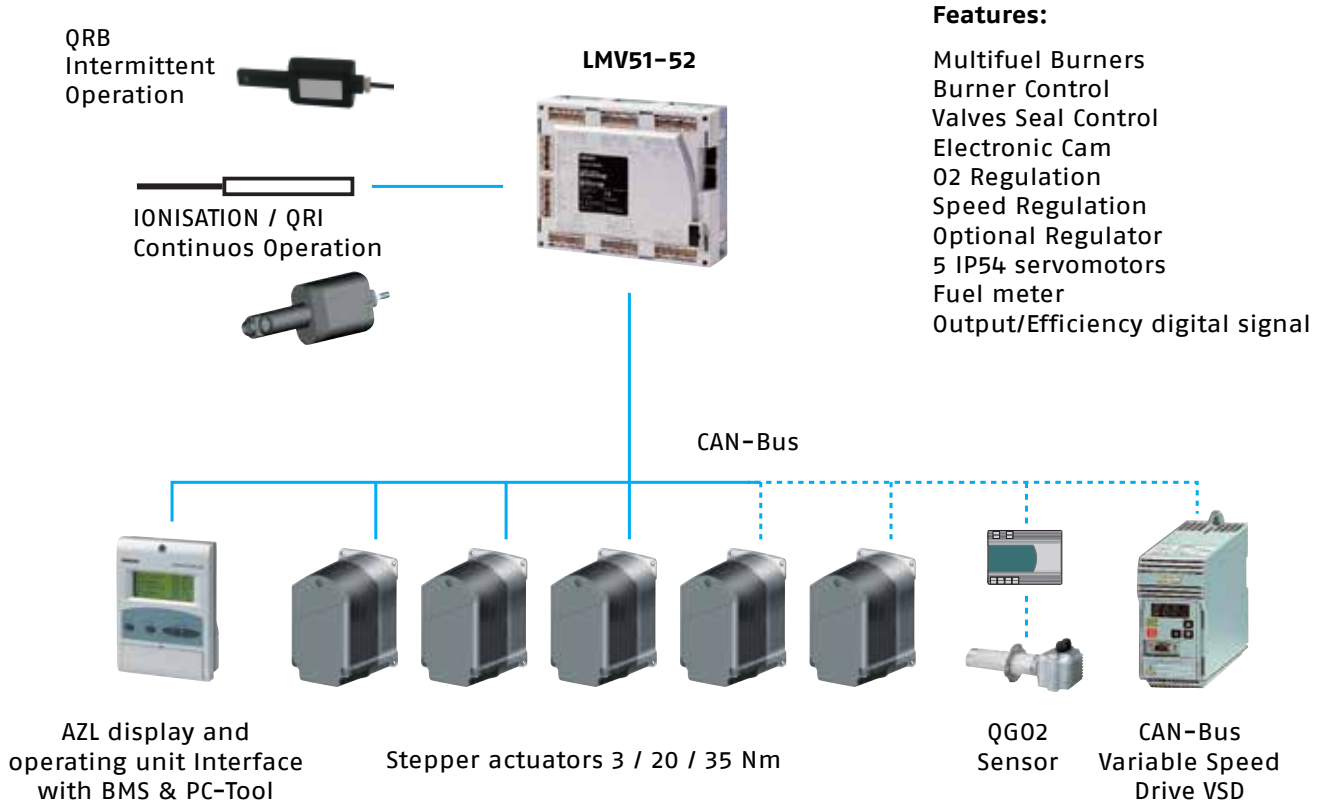

START UP CYCLE

RS 300-400-500-650-800-1000-1200/E-EV BLU

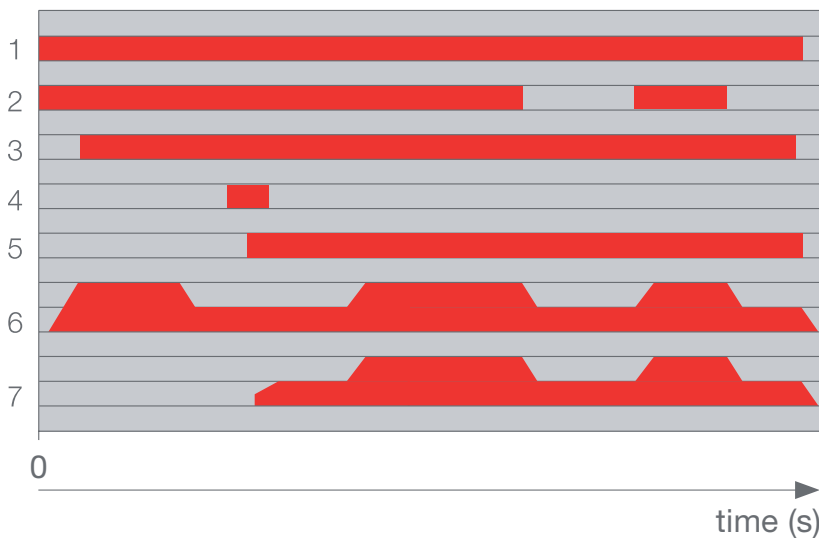

- 1 - Closing thermostat
- 2 - Closing thermostat
- 3 - Fan motor working
- 4 - Ignition transformer
- 5 - Valves open
- 6 - Actuators
- 7 - Flame max. - min.

NO2 EMISSIONS

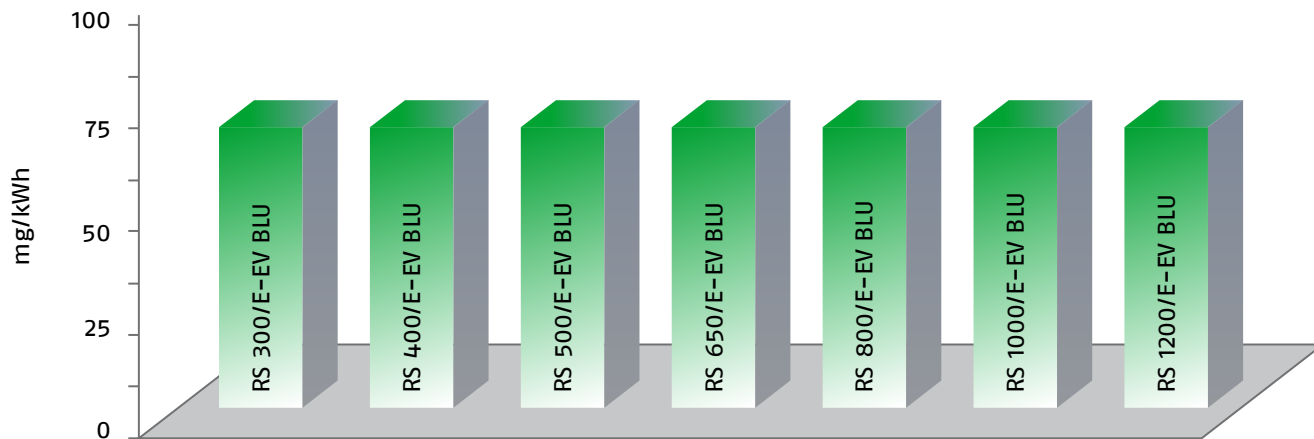

CO EMISSIONS (gas G20)

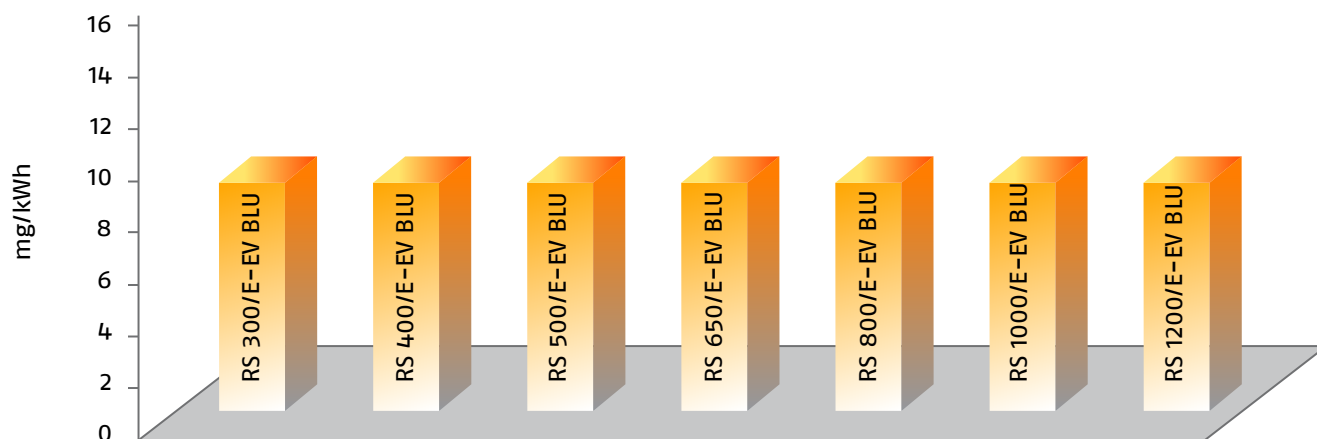

NOISE EMISSIONS

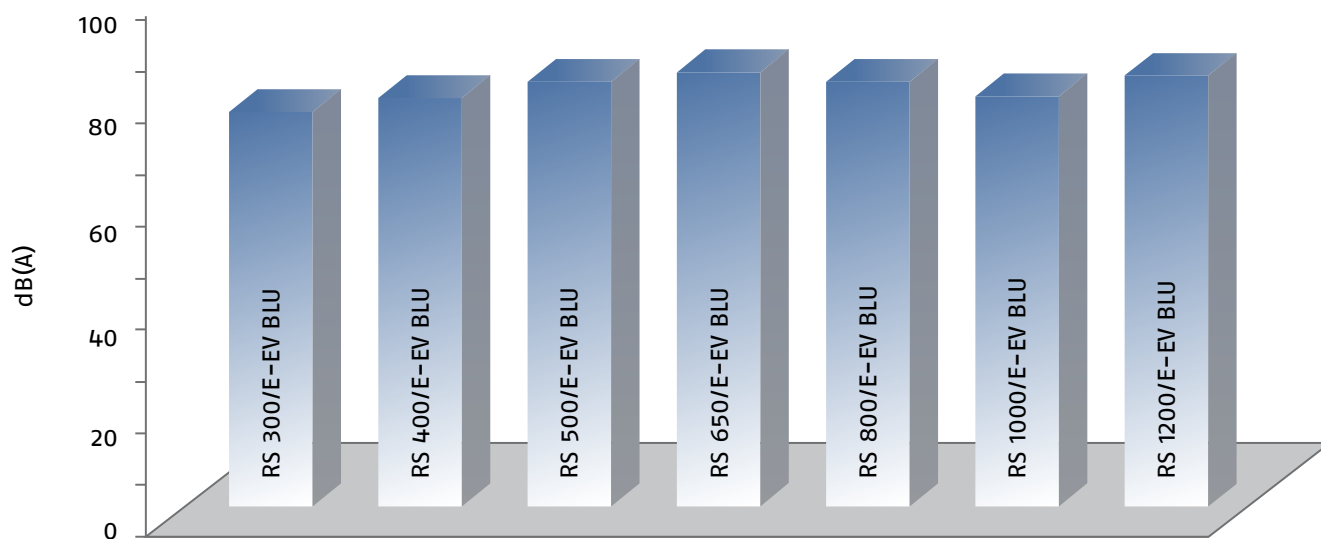

The noise emissions have been measured at the maximum output.

Overall Dimensions (mm)

BURNERS RS 300-400-500-650-800/E-EV BLU

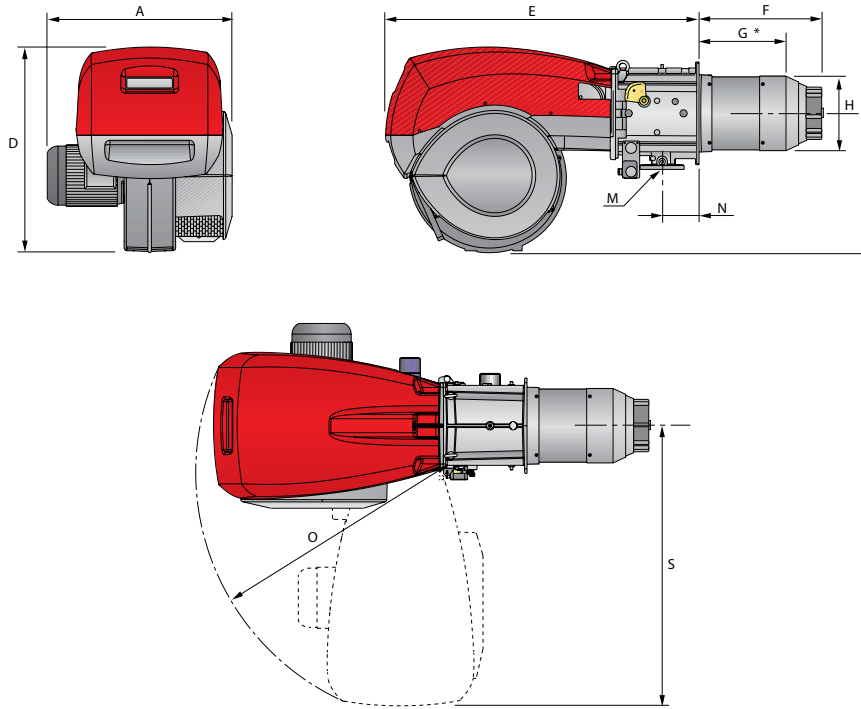

MODEL	A	D	E	F	G*	H	I	M	N	O	S
RS 300/E-EV BLU	720	867	1325	521	373	313	588	DN65	164	1055	1175
RS 400/E-EV BLU	775	867	1325	521	373	313	588	DN65	164	1055	1175
RS 500/E-EV BLU	775	867	1325	521	357	370	588	DN65	164	1055	1175
RS 650/E-EV BLU	800	950	1325	549	397	363	588	DN65/80	175	1055	1175
RS 800/E-EV BLU	940	867	1325	582	418	363	588	DN65/80	164	1055	1175

BURNER - BOILER MOUNTING FLANGE

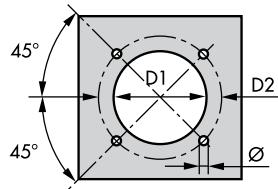

MODEL	D1	D2	Ø
RS 300/E-EV BLU	350	452	M18
RS 400/E-EV BLU	350	452	M18
RS 500/E-EV BLU	390	452	M18
RS 650/E-EV BLU	400	495	M18
RS 800/E-EV BLU	400	495	M18

PACKAGING

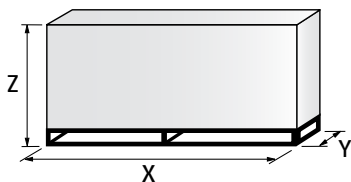

MODEL	X	Y	Z	kg
RS 300/E-EV BLU	1960	945	1100	225
RS 400/E-EV BLU	1960	945	1100	236
RS 500/E-EV BLU	1960	945	1100	250
RS 650/E-EV BLU	2040	1180	1125	300
RS 800/E-EV BLU	2040	1180	1125	300

BURNERS RS 1000-1200/E-EV BLU

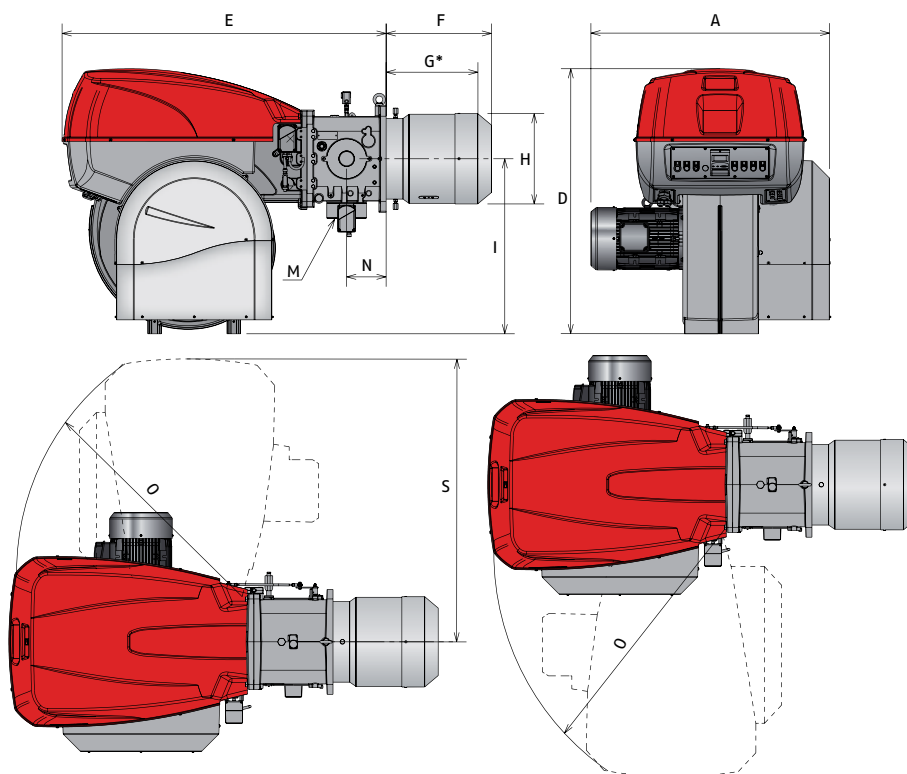

MODEL	A	D	E	F	G*	H	I	M	N	O	S
RS 1000/E-EV BLU	1206	1338	1637	669	485	413	885	DN80	200	1350	1493
RS 1200/E-EV BLU	1250	1338	1637	670	485	456	885	DN80	200	1350	1493

BURNER - BOILER MOUNTING FLANGE

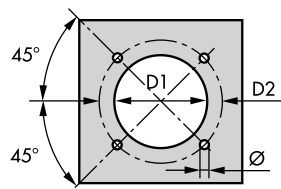

MODEL	D1	D2	Ø
RS 1000/E-EV BLU	460	608	M20
RS 1200/E-EV BLU	500	608	M20

PACKAGING

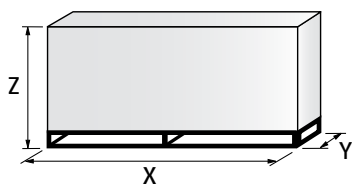

MODEL	X	Y	Z	kg
RS 1000/E-EV BLU	2400	1400	1595	500
RS 1200/E-EV BLU	2400	1400	1595	550

Burner accessories

EXTENDED HEAD KIT

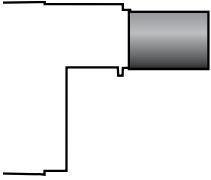

“Standard head” burners can be transformed into “extended head” versions, by using the special kit. The KITS available for the various burners, giving the original and the extended lengths, are listed below.

BURNER	STANDARD HEAD LENGTH (mm)	EXTENDED HEAD LENGTH (mm)	CODE
RS 300-400/E-EV BLU	521 (1) - 373 (2)	621 (1) - 473 (2)	3091427
RS 300-400/E-EV BLU	521 (1) - 373 (2)	671 (1) - 523 (2)	3091919
RS 300-400/E-EV BLU	521 (1) - 373 (2)	721 (1) - 573 (2)	20022815
RS 500/E-EV BLU	521 (1) - 357 (2)	671 (1) - 507 (2)	20028449

(1) referred to quote F
 (2) referred to quote G

VARIABLE SPEED DRIVE (VSD) FOR RS/EV SERIES ONLY



The motor speed variation for the RS/EV BLU burners series is obtained thanks to a frequency converter: variable speed drive (VSD). It always must be ordered with RS/EV series.

BURNER	MAX POWER (KW)	KIT CODE
RS 300-400/EV BLU	7,5	20028307
RS 500/EV BLU	11	3090952
RS 650/EV BLU	18,5	3091174
RS 800-1000/EV BLU	22	3090913
RS 1200/EV BLU	30	20030338

Accessories for modulating operation

POWER CONTROLLER



To obtain modulating operation, the RS/E-EV BLU series of burners requires a regulator with three point outlet controls. The following table lists the accessories for modulating operation with their application range.

BURNER	TYPE	CODE
All models	RWF 40 - Basic version with 3 position output	3010356
	RWF 40 - High version with additional modulating output and RS 485 Interface	3010357

PROBE



The relative temperature or pressure probes fitted to the power controller must be chosen on the basis of the application.

BURNER	TYPE	RANGE (°C) (bar)	CODE
All models	Temperature PT 100	-100 ÷ 500°C	3010110
	Pressure 4 ÷ 20 mA	0 ÷ 2,5 bar	3010213
	Pressure 4 ÷ 20 mA	0 ÷ 16 bar	3010214
	Pressure 4 ÷ 20 mA	0 ÷ 25 bar	3090873

DISPLAY AND OPERATING UNIT (AZL) FOR RS/E MODELS



This tool is needed for combustion system commissioning and monitoring. The AZL, Display and Operating Unit, is included in RS/EV and RS 1000-1200/E-EV models.

BURNER	KIT CODE
RS 300-400-500-650-800/E BLU	3010355
All models *	3010469

* for Russian language only

INFRARED FLAME DETECTOR (IFD)



For the supervision of gas, oil or other flame that emit infrared radiation, the RS/E-EV BLU series of burners can be equipped with infrared flame detector. The infrared flame detector are suited for burners of any capacity, either in continuous or intermittent operation.

BURNER	CODE
All models	3010354

OXYGEN CONTROL KIT (QGO₂) for RS/EV series only



The QGO₂ is an oxygen analyzer with relevant probe which controls and supervises the residual oxygen content in exhaust gases.

BURNER	KIT CODE
All models	3010378
All models	20045187*

* Installation outside the burner cover

KIT EFFICIENCY WITH OXYGEN CONTROL KIT (FOR RS/EV ONLY)



The kit includes two temperature sensors: one for air and one for exhaust gas detection. They must be wired to oxygen control kit interface to allow the LMV 52 efficiency calculation. The value is showed on AZL display.

BURNER	KIT CODE
All models	3010377

PC INTERFACE SOFTWARE (ACS 450)

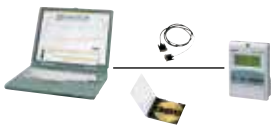

PC tool for convenient programming and burner settings, process visualization, data recording, selection of AZL language, software update AZL.

BURNER	KIT CODE
All models	3010388

SOUND PROOFING BOX

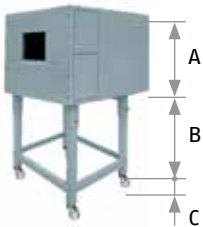

If noise emission needs reducing even further, sound-proofing boxes are available. In case of generator heights, where a lower dimension "B" is required, ask for the Box Support Kit code 20065135.

BURNER	BOX TYPE	A (mm)	B (mm) min. - max	C (mm)	[dB(A)] (*)	CODE
RS 300-400-500/E-EV BLU	C7	1255	160 - 980	110	10	3010376
RS 650-800/E-EV BLU						
RS 1000-1200/E-EV BLU	C8	1700	285 - 1000	110	10	3010401

(*) Average noise reduction according to EN 15036-1 standard

LPG KIT



For burning LPG gas, a special kit is available to be fitted to the combustion head of the burner.

BURNER	CODE
RS 300/E-EV BLU	3010445*
RS 400-500/E-EV BLU	20012916*
RS 650/E-EV BLU	On demand
RS 800/E-EV BLU	20007822*

(*) CE approved

CONTINUOUS VENTILATION KIT



If the burner requires continuous ventilation in the stages without flame, a special kit is available as given in the following table:

BURNER	CODE
All models	3010094

SPACER KIT



If burner head penetration into the combustion chamber needs reducing, varying thickness spacers are available, as given in the following table:





BURNER	SPACER THICKNESS S (mm)	CODE
RS 300-400-500/E-EV BLU	180	20008903
RS 650-800/E-EV BLU		

Gas train accessories

ADAPTERS

In certain cases, an adapter must be fitted between the gas train and the burner, when the diameter of the gas train is different from the set diameter of the burner.

Below are given the available adapters; please see on the Gas Train list the correct adapter codes to select.

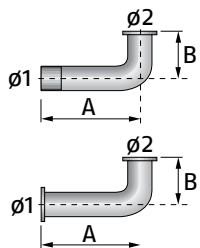
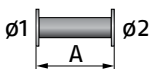
ADAPTER	DIMENSIONS				ADAPTER CODE
	Ø1 DN	Ø2 DN	A mm	B mm	
1" 1/2  2"	-	-	65	-	20064220
2"  2"	-	-	65	-	20042324
DN 80  2" 1/2  2"	-	-	300	-	3000826
	2"	65 / 80	230	230	20064169
	2"	65 / 80	780	230	20068062
	65	65 / 80	230	230	20059330
	80	65 / 80	230	230	20059331
	100	65 / 80	230	230	20059332
	125	65 / 80	245	230	20059333
	2"	65 / 80	230	375	20066253
	2"	65 / 80	780	375	20068058
	65	65 / 80	230	375	20066263
	80	65 / 80	230	375	20066268
	100	65 / 80	230	375	20066278
	125	65 / 80	245	375	20066284
	65	80	400	-	3010221
	80	80	400	-	3010222
	100	80	400	-	3010223
	125	80	320	-	3010224
	65	65	800	-	20065924
	80	80	800	-	20065937
	100	100	800	-	20065960
	125	125	800	-	20065968

STABILISER SPRING

To vary the pressure range of the gas train stabilisers, accessory springs are available. The following table shows these accessories with their application range. Please refer to the technical manual for the correct choice of spring.

GAS TRAIN	SPRING COLOUR	SPRING PRESSURE RANGE mbar	SPRING CODE
MBC 1900/1 - 3100/1 MBC 5000/1	White	4 - 20	3010381
	Red	20 - 40	3010382
	Black	40 - 80	3010383
	Green	80 - 150	3010384
CB 512/1	Red	25 - 55	3010131
	Black	60 - 110	3010157
CB 520/1 - 525/1	Pink	90 - 150	3090486
	Red	25 - 55	3010132
	Black	60 - 110	3010158
CB 5065/1 - 5080/1	Pink	90 - 150	3090487
	Red	25 - 55	3010133
	Black	60 - 110	3010135
	Pink	100 - 150	3090456
CB 50100/1	Grey	140 - 200	3090992
	Red	25 - 55	3010134
	Black	60 - 110	3010136
	Pink	100 - 150	3090489
CB 50125/1	Grey	140 - 200	3092174
	Red	25 - 55	3010315
	Yellow	30 - 70	3010316
	Black	60 - 110	3010317
	Pink	100 - 150	3010318

Specification

DESIGNATION OF SERIES

A specific index guides your choice of burner from the various models available in the RS/M C13 series. Below is a clear and detailed specification description of the product.

Series:		R	
Fuel:		S Natural Gas	
		L Light oil	
		LS Light oil/Natural Gas	
		N Heavy oil	
Size:			
Setting:		/1 Single stage	/E Electronic cam
		/B Two stage	/P Proportioning air/gas valve
		/M Modulating-Mechanical cam	/EV Electronic cam predisposed for variable speed (with inverter)
Emission:		...	Class 1 EN267 - EN676
		MZ	Class 2 EN267 - EN676
		BLU	Class 3 EN267 - EN676
		MX	Class 2 EN267
			Class 3 EN676
Head length:		TC standard head	
		TL extended head	
Flame control system:		FS1 Standard (1 stop every 24 h)	
		FS2 Continuous working (1 stop every 72 h)	
Electrical supply to the system:			
		1/230/50	1/230V/50Hz
		3/230/50	3/230V/50Hz
		3/400/50	3N/400V/50Hz
		3/230-400/50	3/230V/50Hz - 3N/400V/50Hz
		3/220/60	3/220V/60Hz
		3/380/60	3N/380V/60Hz
		3/220-380/60	3/220/60Hz - 3N/380V/60Hz
Auxiliary voltage:		230/50-60	230V/50-60H
		110/50-60	110V/50-60Hz

R	S	500	/E	BLU	TC	FS1	3/230-400/50	230/50-60
BASIC DESIGNATION				EXTENDED DESIGNATION				

AVAILABLE BURNER MODELS

BURNER MODELS	HEAD LENGTH	FLAME CONTROL SYSTEM	ELECTRICAL SUPPLY	AUXILIARY VOLTAGE
RS 300/E BLU	TC	FS1/FS2	3/230-400/50	230/50-60
RS 400/E BLU	TC	FS1/FS2	3/230/50	230/50-60
RS 400/E BLU	TC	FS1/FS2	3/400/50	230/50-60
RS 500/E BLU	TC	FS1/FS2	3/400/50	230/50-60
RS 650/E BLU	TC	FS1/FS2	3/400/50	230/50-60
RS 800/E BLU	TC	FS1/FS2	3/400/50	230/50-60
RS 1000/E BLU	TC	FS1	3/400/50	230/50-60
RS 1200/E BLU	TC	FS1	3/400/50	230/50-60
RS 1000/E BLU	TC	FS1	3/400/50	230/50-60
RS 1200/E BLU	TC	FS1	3/400/50	230/50-60
RS 300/EV BLU	TC	FS1/FS2	3/230-400/50	230/50-60
RS 400/EV BLU	TC	FS1/FS2	3/400/50	230/50-60
RS 500/EV BLU	TC	FS1/FS2	3/400/50	230/50-60
RS 650/EV BLU	TC	FS1/FS2	3/400/50	230/50-60
RS 800/EV BLU	TC	FS1/FS2	3/400/50	230/50-60
RS 1000/EV BLU	TC	FS1	3/400/50	230/50-60
RS 1200/EV BLU	TC	FS1	3/400/50	230/50-60
RS 1000/EV BLU	TC	FS1	3/400/50	230/50-60
RS 1200/EV BLU	TC	FS1	3/400/50	230/50-60

Other versions are available on request.

SPECIFICATION

STATE OF SUPPLY

Monoblock forced draught gas burner with modulating operation, fully automatic, made up of:

- High performance fan with low sound emissions, reverse curve blades for RS 300-400-500-1000-1200/E-EV BLU, forward curve blades for RS 650-800/E-EV BLU
- Air suction circuit lined with sound-proofing material
- Air damper for air setting controlled by a high precision servomotor
- Air pressure switch
- Fan starting motor at 2900 rpm, three-phase 230/400 - 400/690 V with neutral, 50Hz
- Low emission mobile combustion head, that can be set on the basis of required output, fitted with:
 - stainless steel end cone, resistant to corrosion and high temperatures
 - ignition electrodes
 - flame stability disk
- Automatic regulator for gas delivery, controlled by a high precision servomotor
- Maximum gas pressure switch, with pressure test point, for halting the burner in the case of over pressure on the fuel supply line
- Module for air/fuel setting and output modulation with separated PID control of temperature or pressure, available as accessory for RS/E BLU model
- Module for air/fuel setting and output modulation with incorporated PID control of temperature or pressure of the heat generator (RS/EV BLU)
- AZL Display Interface, for combustion system commissioning and monitoring, included in RS/EV models and RS 1000-1200/E (Available as accessory for RS 300-400-500-650-800/E BLU models)
- Burner safety control included on Electronic Cam device
- Ionization probe for flame detector for RS 300-400-500-650-800 and IRD sensor for RS 1000-1200
- Star/triangle starter for the fan motor (burners with motor electrical power > = 7,5 kW, RS/E)
- Main electrical supply terminal board
- Burner on/off switch
- Auxiliary voltage led signal
- Manual or automatic output increase/decrease switch
- Burner working led signal
- Contacts motor and thermal relay with release button
- Motor internal thermal protection
- Motor failure led signal
- Burner failure led signal and lighted release button
- Emergency button
- Coded connection plugs-sockets
- Burner opening hinge
- Lifting rings
- IP 54 electric protection level
- The gas supply connector DN 80 for gas train connection (RS 300-400-500 models)

Standard equipment:

- 1 flange gasket
- 4 screws for fixing the flange
- 1 thermal screen
- 4 screws for fixing the burner flange to the boiler
- Seal control pressure switch (for installation on gas train)
- Instruction handbook for installation, use and maintenance
- Spare parts catalogue.

Gas train

Fuel supply line, in the MULTIBLOC configuration (for a diameter of 1-1/2" and 2") or COMPOSED configuration (from a diameter of DN 65 until a diameter of DN 125), fitted with:

- Filter
- Stabiliser
- Minimum gas pressure switch
- Safety valve
- One stage working valve with ignition gas output regulator.

Conforming to:

- 2004/108 EC directive (electromagnetic compatibility)
- 2006/95 EC directive (low voltage)
- 2009/142 EC directive (gas)
- 2006/42 EC directive (machine)
- EN 676 (gas burners).

Available accessories to be ordered separately:

- Extended head kit
- Variable speed drive (VSD) for RS/EV series only
- Accessories for modulating operation
- Display and operating unit (AZL) for RS/E models
- Power controller
- Probe
- Infrared flame detector (IFD)
- Oxygen control kit (QGO₂) for RS/EV series only
- Kit efficiency with oxygen control kit (for RS/EV only)
- PC interface software (ACS 450)
- Sound proofing box
- LPG kit
- Continuous ventilation kit
- Spacer kit
- Adapters
- Stabiliser spring

Riello Burners a world of experience in every burner we sell.



[1]

Across the world, Riello sets the standard in reliable and high efficiency burner technology.

With burner capacity from 5 kW to 48 MW, Riello gas, oil, dual fuel and Low Nox burners deliver unbeatable performance across the full range of residential and commercial heating applications, as well as in industrial processes.

With headquarter in Legnago, Italy, Riello has been manufacturing premium quality burners for over 90 year. The manufacturing plant is equipped with the most innovative systems of assembling lines and modern manufacturing cells for a quick and flexible response to the market.



[2]

Besides, the Riello Combustion Research Centre, located in Angiari, Italy, represents one of the most modern facility in Europe and one of the most advanced in the world for the development of the combustion technology.

Today, the company's presence on worldwide markets is distinguished by a well-constructed and efficient sales network, alongside many important Training Centres located in various countries to meet its customers' needs. Riello has 13 operational branches abroad (in Europe, America and Asia), with customers in over 60 countries.

[1] BURNERS PRODUCTION PLANT
S. PIETRO, LEGNAGO (VERONA) - ITALIA

[2] HEADQUARTER BURNERS DIVISION
S. PIETRO, LEGNAGO (VERONA) - ITALIA

RIELLO S.p.A. - 37045 Legnago (VR) - Italy
tel. +39 0442 630111 - fax: +39 0442 21980
www.riello.com

Since the Company is constantly engaged in the production improvement, the aesthetic and dimensional features, the technical data, the equipment and the accessories can be changed. This document contains confidential and proprietary information of RIELLO S.p.A. Unless authorised, this information shall not be divulged, nor duplicated in whole or in part.

RIELLO